

# TELEVISION

THE FIRST TELEVISION JOURNAL IN THE WORLD

NEW SERIES  
PUBLISHED BY THE PROPRIETORS OF  
"AMATEUR WIRELESS"  
AND  
"WIRELESS MAGAZINE"

SEPTEMBER, 1934. No. 79

• •

## The Latest German Progress

Fully Illustrated

• •

## Getting the Best From your Neon

MONTHLY  
ONE SHILLING  
NET

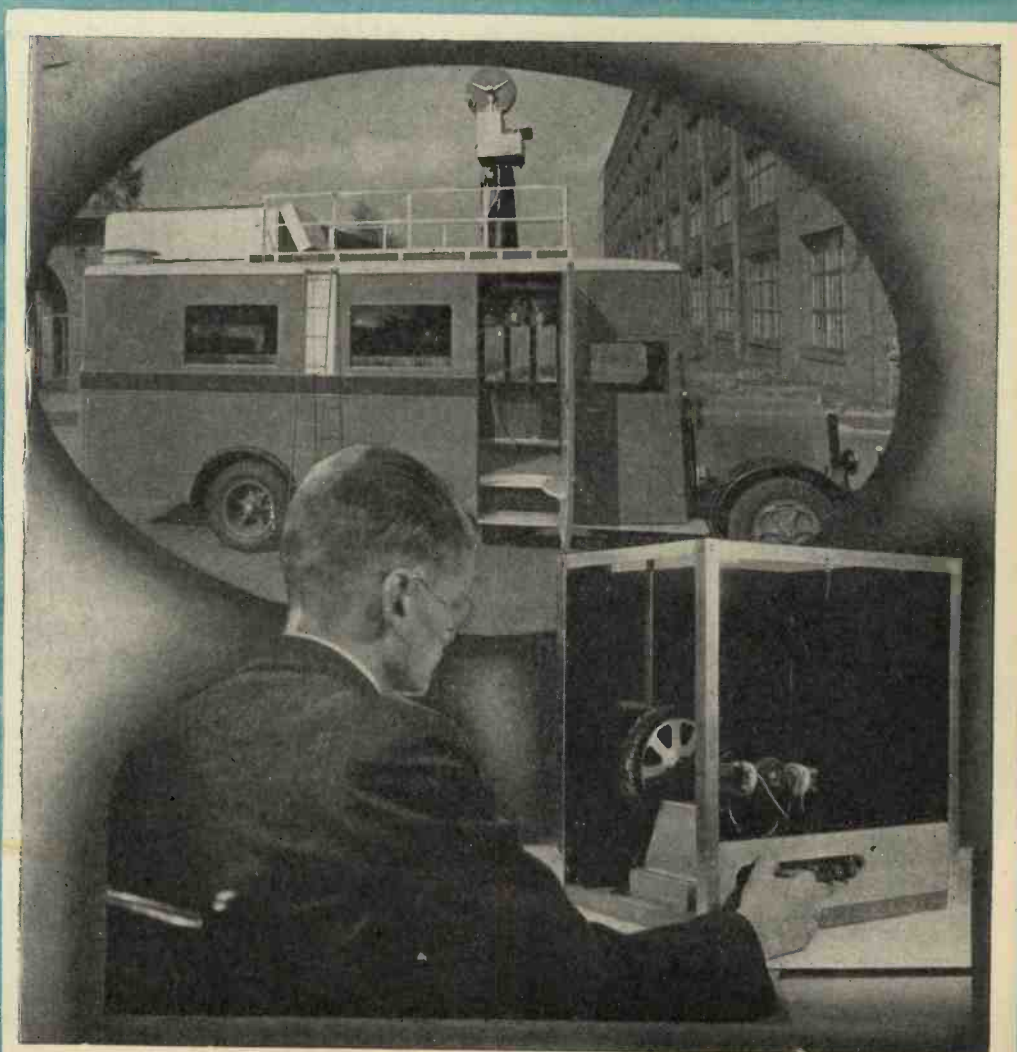

**THE SIMPLEST MIRROR-DRUM RECEIVER**—How to make it.  
(Above): The Fernseh A.G. Mobile Intermediate Film Transmitter.

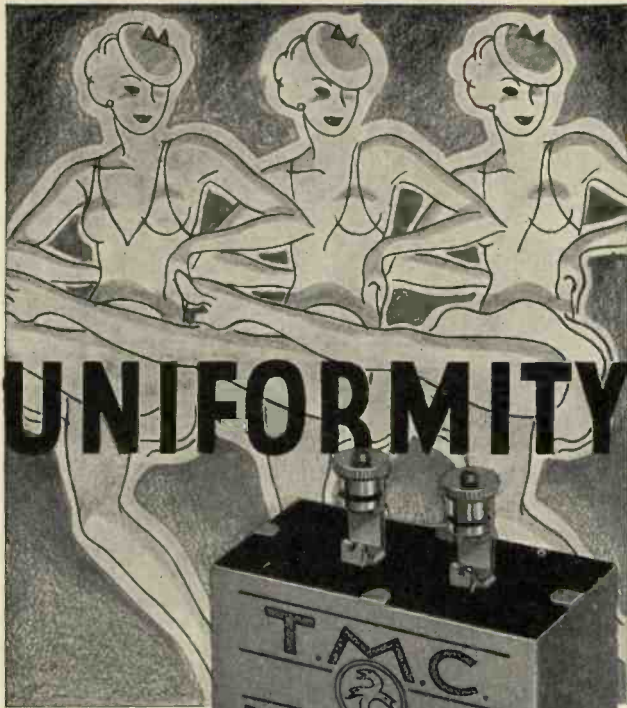

The perfect uniformity of movement in a well-trained chorus is not as easy to achieve as it looks. It calls for experience, endless practice and endless patience. So it is with T.M.C.-HYDRA condensers. Patient and careful checking is carried out at every stage in their manufacture. Stringent tests are applied to ensure uniform accuracy within the narrowest of limits. And so you know that every T.M.C.-HYDRA condenser you buy is absolutely reliable.

**T.M.C.**  
BRITISH MADE  
**HYDRA**  
CONDENSERS



The special method of sealing T.M.C.-HYDRA condensers definitely prevents the penetration of moisture and so preserves the high electrical properties of the condensers. T.M.C.-HYDRA condensers of all types are sold by your radio dealer, but if you have any difficulty in obtaining supplies, write to the Sole Distributors:

**T.M.C.-HARWELL (SALES) LTD**  
Britannia House, 233 Shaftesbury Avenue  
London, W.C.2. (A few doors from New Oxford Street)  
Telephone: Temple Bar 0055 (3 lines)

Made by TELEPHONE MANUFACTURING Co., Ltd.

# The FIRST STENODE

for the  
**CONSTRUCTOR!**

The greatest need in radio sets to-day is selectivity, and the most up-to-date selective circuit that has ever been invented is Dr. James Robinson's STENODE. In the September WIRELESS MAGAZINE, a set using this circuit—approved by Dr. Robinson himself—is described for the benefit of home constructors by Paul Tyers, one of the best-known designers in the radio trade. It is the first of its type ever offered to the home constructor and will set a new fashion in sets for the coming season.

The demand for the September issue will be very heavy and you would be well advised to get a copy without delay—price 1/- from all newsagents.

# WIRELESS MAGAZINE

SEPTEMBER ISSUE

PRICE 1/-

Advertisers like to know you saw it in "Television"



*it is here!*



# TELEVISION

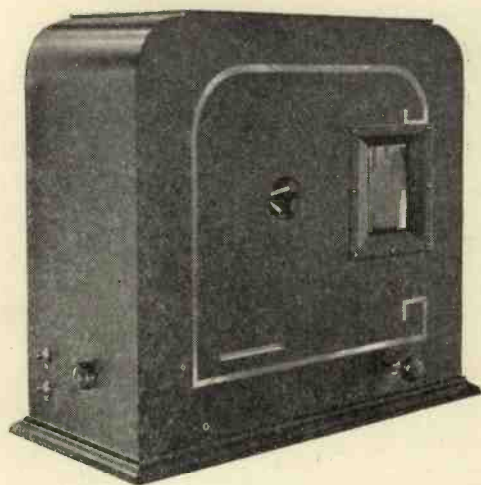

*man's strangest dream comes true in your own home.....*

Plew researches . . . extending over a quarter of a century . . . at last bear fruit. A method has been perfected. Clear, steady Television for the home at a price all can afford . . . becomes suddenly practicable. See as you listen . . . the greatest thrill of this new age. Programmes are to be greatly extended . . . get in touch with your dealer today . . . be in the forefront of the most exciting discovery the radio world has known.

# PLEW

MODEL NO. 1	<b>10 gns.</b>
STANDARD MODEL	<b>18 gns.</b>
LONG RANGE	<b>22 gns.</b>
<b>TELEVISION</b>	

PLEW TELEVISION LTD., STAFFORD ROAD, WADDON, SURREY. Tel.: FAIRFIELD 5191.

Better service results from mentioning "Television" when writing to advertisers

# TELEVISION

COSTING NO MORE THAN A GOOD MOVING COIL SPEAKER

## THE SIMPLEST MIRROR DRUM RECEIVER

THE "UNISPHERE" MIRROR DRUM KIT is now available at the new price of £2/15/- Post Free. In the standard Unisphere Kit the mirrors are assembled to the carriers ready for fixing and adjusting, but in this new Kit the mirrors are not assembled. This operation is easily carried out, each mirror being held by two small clips.

A CRATER LAMP for Screen Pictures with the "UNISPHERE" MIRROR DRUM easily giving brilliant lighted pictures 7" by 3". Large pictures can be obtained, but have less illumination. Special NU-GLO type, Striking Voltage 200v. to 250v., with a maximum carrying capacity of 30 milliamps D.C.; the luminous aperture is square. LOW PRICE of 37/6 Post Free.

B.M. 3 MOTOR. Ideal for driving "UNISPHERE" Mirror drum only £1

Fixed Resistance ... .. 4/-  
Variable Resistance ... .. 6/6  
Toggle Switches ... .. 1/- each

## ADDITIONAL

### COMPONENT PARTS FOR THE EXPERIMENTAL TELEVISION TRANSMITTER

Additional to the list of Mervyn Transmitter Parts specified in last month's issue.

CHASSIS WOODWORK, complete ... .. 3/6  
Fifteen ERIE RESISTANCES 15/-  
Ten T.C.C. CONDENSERS 22/2  
FIVE VALVE-HOLDERS, Chassis mounting 5-pin ... .. 3/9

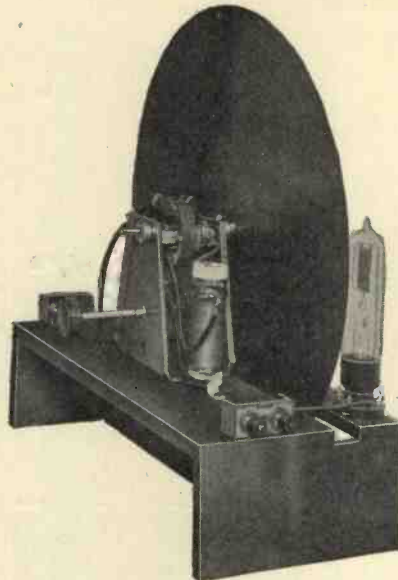

Actual Photograph of MERVYN TELEVISION KIT ASSEMBLED

KIT OF PARTS only

£3 : 0 : 0

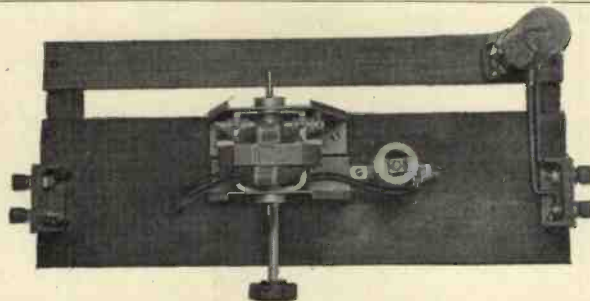

Photograph showing plan of Mervyn Television Kit assembled

## EASY TO ASSEMBLE — DEFINITE RESULTS

The Mervyn Television Kit is quite easy to assemble with a few simple tools, and can be worked from almost any type of Receiver (Battery or Mains). Although offered at the low price of £3 the set of parts include the famous Mervyn Nu-Glo 16 Lamp which was exclusively specified in the popular Daily Express Kit. Here is a great opportunity for the enthusiast to obtain for a small outlay a complete set of tested parts, that definitely will bring pictures into the home.

### LIST OF PARTS INCLUDED IN THE MERVYN TELEVISION KIT

- |   |                                   |   |
|---|-----------------------------------|---|
| (1) 1 B.D. 4 Disc. 15½ in. Diameter ... 6/- | (4) 1 Variable Resistance ... 6/6 | (7) 2 pairs of Terminals and blocks ... 2/-                         |
| (2) 1 B.M. 3 Universal Motor ... 20/-       | (5) 1 Fixed Resistance ... 4/-    | (8) 1 Mervyn Nu-Glo 16 Lamp (as used in the Daily Express Kit) 12/6 |
| (3) 1 Pair Motor Brackets ... 5/6           | (6) 1 Lamp Holder 9d.             | (9) Baseboard parts 3/6   |

PRICE OF PARTS

£ 3 : 0 : 0

COMPLETE

YOU CAN RELY ON MERVYN FOR ALL TELEVISION COMPONENTS AND SETS.

Write for advice and details of Television and Radio apparatus, or any component part you may require to :

# THE MERVYN SOUND & VISION CO. LTD.

4, HOLBORN PLACE, LONDON, W.C.1.

Managing Director : W. J. NOBBS. Telephones : Holborn 6332 and 7709.

French Office: 8, Square Henri-Delormel Paris 14e

It helps us if you mention "Television"



# TELEVISION

THE FIRST TELEVISION JOURNAL IN THE WORLD

## In This Issue

Full constructional details of a very simple type of mirror-drum receiver which will give a screen picture seven inches by three inches.

\* \* \*

The latest news of German developments as revealed at the Berlin Radio Exhibition.

\* \* \*

A section for the beginner.

\* \* \*

An article detailing the improvements that have recently been made in cathode-ray tubes.

\* \* \*

Instructions for getting the best results from the neon lamp.

\* \* \*

An account of the Loewe demonstration of 180-line television in London.

\* \* \*

A well-reasoned article on the subject of definition.

\* \* \*

An explanation of arc-light modulation.

\* \* \*

Details of a standard light source for the experimenter.

\* \* \*

Droitwich and Television.

\* \* \*

The latest methods of cutting out interference.

\* \* \*

Recent developments, etc., etc.

## TELEVISION

*Proprietors:*

BERNARD JONES PUBLICATIONS, LTD

*Editor-in-Chief:*

BERNARD E. JONES.

*Editor:*

H. CORBISHLEY.

*Editorial, Advertising and Publishing*

*Offices:*

58-61, Fetter Lane, London, E.C.4.

Telephone: Central 4341 (four lines).

Telegrams: Beejapee, Fleet, London.

*Subscription Rates:* Post paid to any part of the world—3 months, 3/6; 6 months, 6/9; 12 months, 13/6.

Published Monthly—1/- net.

(Last Wednesday in every month for following month).

Contributions are invited and will be promptly considered. Correspondence should be addressed, according to its nature, to the Editor, the Advertisement Manager, or the Publisher, "Television," 58-61, Fetter Lane, London, E.C.4.

## COMMENT OF THE MONTH

### *How the Amateur Can Help.*

IT is perhaps natural that at the present time, pending a decision of the Postmaster-General's Committee on the future of television in this country, there should be a certain amount of apathy by many people as regards active participation in the science. The contention is that the half hour transmission per week which is all that is available to most people is not worth the expense and trouble entailed. From this point of view we are partly in agreement, but may we point out that apart from any transmissions whatsoever there is a vast field of interest for the amateur experimenter which will entail very little expense in investigating. This field includes such varied subjects as wireless, optics, light and mechanics. It appears fairly certain that eventually successful television development will be upon the ultra-short waves and here is a subject of which only the fringe has been touched so far as the needs of television are concerned. The wireless enthusiast might with advantage make himself *au fait* with the peculiarities of short-wave reception.

Then there are the problems of scanning and the possibility, or otherwise, of projecting the picture as a whole instead of in units. Recent research has indicated considerable progress in this direction and it is quite likely that further developments will be made by individual workers. From the point of view of efficiency present television practice compares very unfavourably with that of the cinema. There are difficulties in the modulation of light; our present methods are extremely inefficient though within quite recent times research has made possible increased efficiency. The same remarks apply to a light source that can be modulated directly.

One of the limitations of the successes that have been demonstrated in the last few months is that of the size of the image. Our screens are measured in inches instead of feet and this fact is recognised as one of the drawbacks of systems employing the cathode-ray tube; the same problem is present with mechanical systems because of the amount of modulated light that can be made available.

The foregoing only represent a fraction of the problems waiting solution though they are perhaps the major ones. They are, however, problems that for the most part definitely come within the scope of the amateur wireless worker, as did many wireless problems in the early days of broadcasting and which the amateur did so much towards solving. We wish to stress the point that many of them can be tackled with but small expenditure, that they can be investigated either individually or as a whole and irrespective of any transmissions that are available. In order to encourage work of this nature we propose publishing a series of articles of an experimental nature and describing the equipment of a complete television laboratory with constructional details of the necessary apparatus where this is possible. Our object in doing this is to enlist the services of a large band of enthusiasts who we are confident will do much to advance the development of television.

:: A SPECIAL CONTRIBUTION BY MR. J. L. BAIRD NEXT MONTH ::



In this photograph two of the sides are removed to show the interior.

THE great advantages of the mirror-drum receiver are that it gives screen projection and that the size of the picture compared with that obtained with the disc machine is reasonably large—the size in fact is sufficient for it to be viewed by a number of people without difficulty. Additionally there are the advantages that the picture is practically black and white and no viewing lens is necessary which can cause distortion. The mirror-drum visor is, in fact, the best of the various types of receivers which are available to the amateur.

It is perhaps natural that to obtain these advantages some amount of added complications are necessary and the object in the present design has been to make these as simple as possible consistent with a good design and compactness. When the design is considered later it will be appreciated that in some respects it could be further simplified, but only at the cost of making the apparatus somewhat clumsy in appearance. The entire chassis of this receiver can be accommodated in a cabinet but little larger than the average radio receiver and as the whole of the visor is self-contained in the metal chassis it can be withdrawn *en bloc* for adjustment,

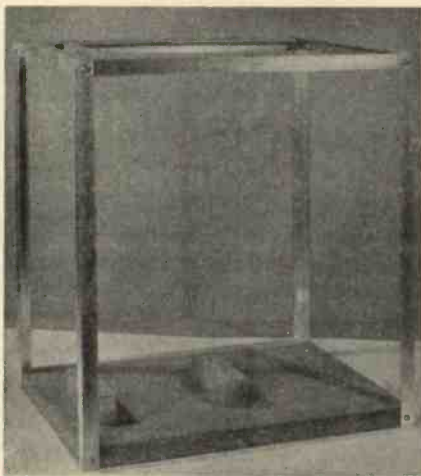

The frame is of aluminium angle riveted together.

# THE MIRROR-

*Describing the construction design that can be built*

etc. To make this possible it has been necessary to use an additional mirror at the top of the instrument.

Standard parts have been used throughout with the exception of a few details which any amateur can easily make himself. The list of these parts is given overleaf.

## A New Light Source.

In order to keep the construction as simple as possible a directly modulated light source has been used and in the actual receiver shown this is a mercury-vapour recording tube of the type made for recording on film obtainable from the General Electric Co., Ltd. This, incidentally is the first machine which has been described using this type of lamp which has recently come into considerable favour for this purpose. Alternatively a neon lamp of the crater point type could be used.

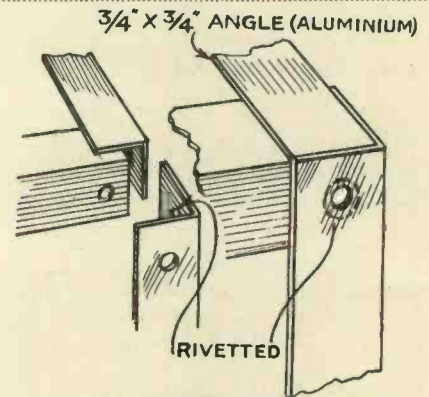

Detail showing how the frame is assembled and secured with rivets.

The use of either of these two types of lamp reduces the complication of assembly and working very considerably for as the light is modulated directly there is no necessity for a light valve of the Kerr cell type with its consequent critical optical assembly.

The optical arrangement will be quite clear from the photographs and drawings. The recording tube is masked so that a point source of light is obtained and immediately in front is a flat plate of brass with an adjustable aperture (an item which it is recommended should be purchased); next there is a lens and behind this a mirror which reflects the light on the mirror drum and from here it is reflected on to the mirror



# THE SIMPLEST DRUM RECEIVER

*of a mirror-drum receiver of compact and simple at the minimum expense with simple tools and materials.*

placed near the top of the chassis which in turn reflects it on to the screen.

All these parts are assembled so that they are adjustable within fairly wide limits, but, if it is desired, the optical unit can be obtained as a complete unit mounted on an aluminium chassis. The constructor has, therefore, the option of mounting the lamp holder, lens and mirror separately, or simply using the complete unit and fixing this in place.

Various means are available of mounting the separate parts and in the present instance brass curtain rail was used and the small sliders which are sold with this was fitted to the parts by soldering; this arrangement allows of quick and easy adjustment to secure the most suitable positions. If these units are assembled in the positions shown they will be about correct but some small amount of adjustment will be found quite essential.

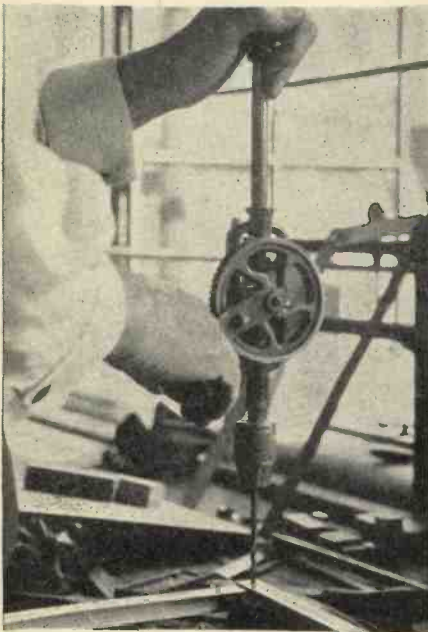

*When drilling the frame members the two parts should be placed together.*

in an aluminium chassis constructed of  $\frac{3}{4}$  in. aluminium angle. In some of the photographs this is shown with two sides filled in with plywood secured on the inside, but this it not necessary if the whole assembly is to be fitted into a cabinet. A detail sketch shows how the

corners of the aluminium angle are secured together with 3-16 in. aluminium rivets. The bottom ends of the chassis members

are simply screwed to the baseboard. The construction of the chassis of this description is quite a simple matter, for it only means drilling a few holes in soft metal and riveting the pieces together. Photographs show the operations of drilling and riveting the metal

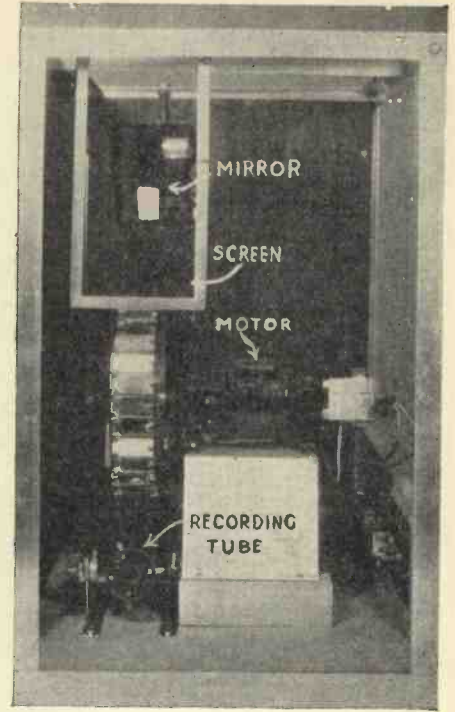

*Here is a front view showing the mirror-drum and recording tube.*

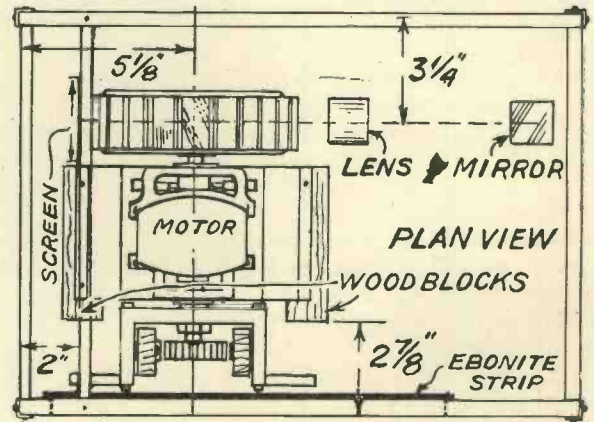

*Plan view showing the layout of the baseboard.*

### The Chassis

As mentioned before the entire apparatus is contained with-

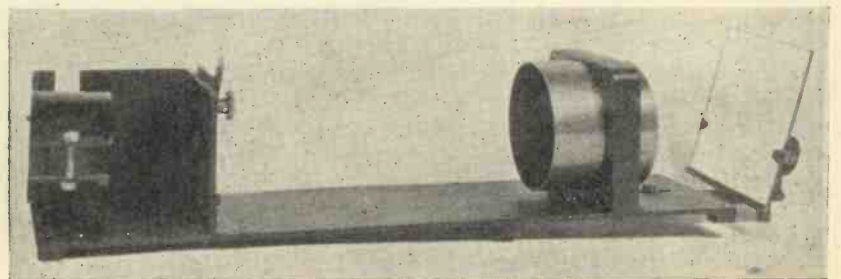

*A complete optical unit is available if it is wished to simplify construction.*



Here is a view of the complete receiver.

and it should be noted that when drilling, the two parts should be held together so that the holes will be in alignment.

The motor with mirror drum and synchronising gear are mounted on a metal stand which is supplied with the motor and brought to the correct height by supporting the stand upon two blocks of wood.

There is an additional member across the top of the chassis which supports the frame which holds the screen. This frame is made of thin sheet brass bent into U section and then sawn nearly through at the positions of the corners and bent at right angles. It is secured to the top cross member by two small bolts and nuts. Incidentally it should be noted that this cross member is not riveted as are the other members, but is secured by small bolts and nuts; this is necessary for purposes of assembly.

Although the position of this member which holds the screen is given, this should be regarded as approximate and it should not be finally fixed until a test has been made as in all probability the screen position will require adjustment in order to bring the scanning spot to the correct focus.

It will be observed that the switch panel, which is of ebonite, is mounted at the back of a piece of wood which occupies the bottom of one side of the chassis. This wooden panel adds considerably to the rigidity of the chassis and even if it is decided to mount the switches and terminals elsewhere should not be omitted. On this same panel is the variable resistance for the speed control of the motor.

The uses of the six terminals are as follows: one pair for the connections of the mains to the motor; one pair for the recording lamp and one pair for the synchronising coils. A switch is placed in series with the terminals in each lead and in the case of the motor the variable resistance and a fixed resistance (which latter is placed on the baseboard) are

also included. If desired mains plugs and sockets could be used instead of the terminals and probably in the case of the motor this would be more satisfactory as there would then be no risk of shorting the mains should the wires become detached.

The construction of the frame which holds the screen is shown in detail and it is very simple; there is no

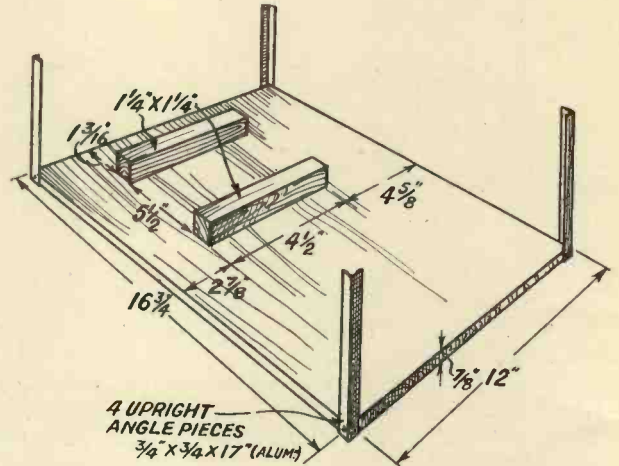

This sketch shows how the chassis angle pieces are fixed to the baseboard.

### PARTS AND MATERIALS REQUIRED.

- THIRTY-LINE MIRROR-DRUM. (Mervyn.)
- MOTOR AND STAND. (British Television Supplies.)
- SYNCHRONISING GEAR. (British Television Supplies.)
- VARIABLE AND FIXED MOTOR RESISTANCES. (British Television Supplies.)
- 12 ft.  $\frac{1}{2}$  in. ALUMINIUM ANGLE. (Peto Scott.)
- 6 TERMINALS. (Belling-Lee.)
- 2 REFLECTING MIRRORS. (Mervyn.)
- RECORDING TUBE, TYPE D2 (G.E.C.) or CRATER-POINT LAMP. (Mervyn.)
- LENS. (Sanders.)
- BASEBOARD, CONNECTING WIRE, EBONITE PANEL, ETC. (Peto-Scott.)
- 3 ON-OFF MAINS SWITCHES. (Bulgin.)
- ALTERNATIVE OPTICAL UNIT. (Sanders.)

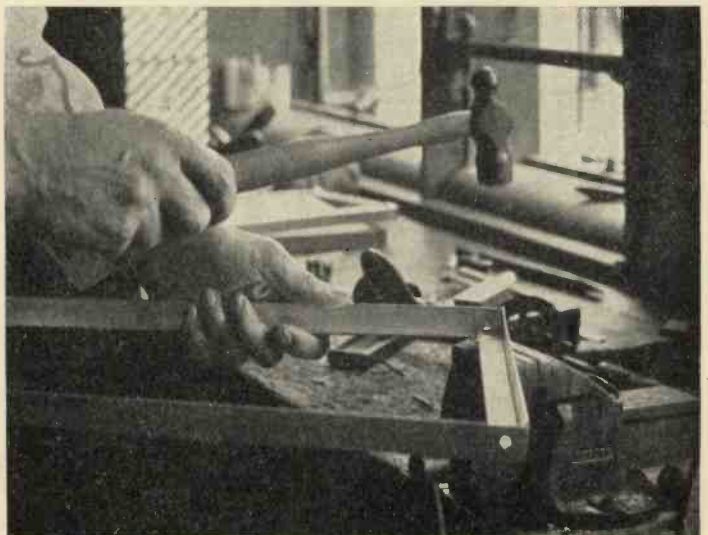

It is quite a simple matter to rivet the frame together.



reason why a frame made of wood should not be substituted if this is preferred; in fact the same remarks apply to the chassis frame if it is preferred to work in wood instead of metal. It should be borne in mind, however, that the chassis must be rigid so that it will not vibrate when the motor is running.

It should be noted that as there are two reflecting mirrors used in this receiver, it is necessary for the mirrors of the drum to be set at the opposite angle to

to cause it to strike than its normal operating voltage. There are various schemes with which this can be simply accomplished and one of these is shown by the diagram. In this case a high-inductance choke is connected so that it can be momentarily put into circuit by means of a press button; the surge voltage thus produced is sufficient to cause the lamp to strike and it will then continue under normal working conditions.

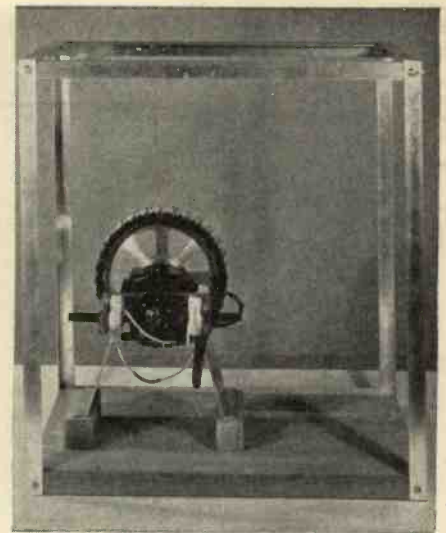

In this photograph the chassis is shown completed with the motor in position.

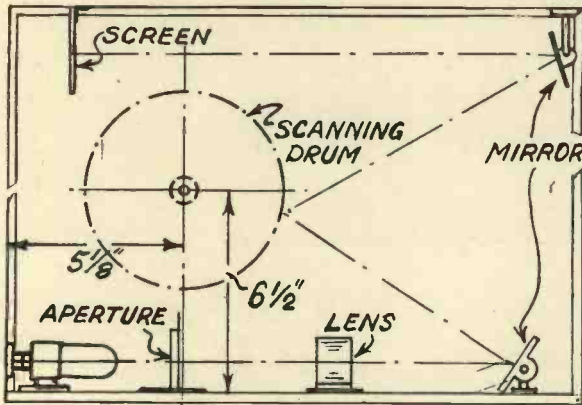

Diagram showing the optical arrangements of the receiver.

that necessary when only one mirror is used as, of course, a reversal takes place. This matter should be mentioned when ordering the drum, or care taken to make the assembly of the mirrors on the drum with the correct setting if this is built up from a kit of parts. The scanning spot, of course, starts at the bottom right-hand corner of the screen, travels upwards and as each line is completed moves one spot width to the left until the whole scan is completed. A test with a couple of mirrors in position will soon make it quite clear how the mirrors should be placed.

### Starting the Tube

If a recording tube is used as the light source it will be found that a higher initial voltage will be required

Even though the measurements given in the drawings are adhered to exactly it will be found that a certain amount of final adjustment will be required and on this account it is as well not to fasten the parts down permanently until a test of the optical assembly has been made; it will be understood that there is a considerable amount of optical leverage and that a small error in the placing of the parts will be magnified very greatly. As few screws as possible should therefore be inserted in the first place so that the parts can be moved slightly to secure the best positions.

The object should be to arrange that the scanning spot starts at the bottom right-hand corner of the screen and covers the whole area in a succession of lines. It is equally important that the spot be sharply defined at all positions on the screen and in order to secure this some adjustment of the mirrors will be necessary and possibly the angle at which the screen is placed relative to the chassis. It may be found desirable to tilt this a little one way or the other.

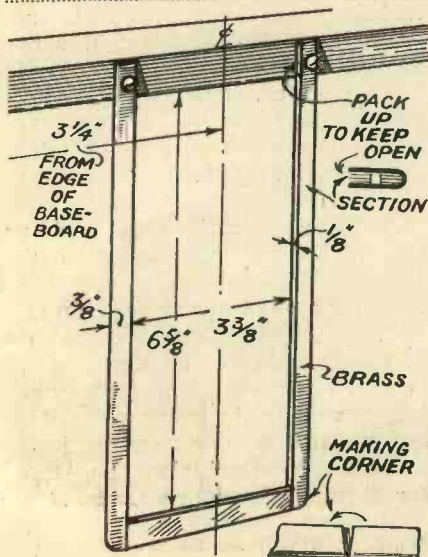

Left. Details of construction of the screen frame.

Below. Circuit showing how a high-inductance choke is used to cause the recording tube to strike.

Right. Details of terminal and switch panel and wood mount.

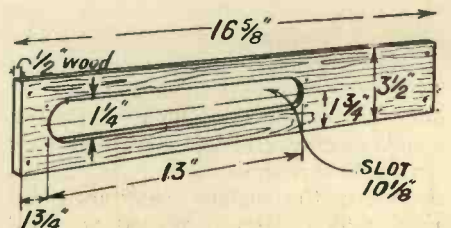
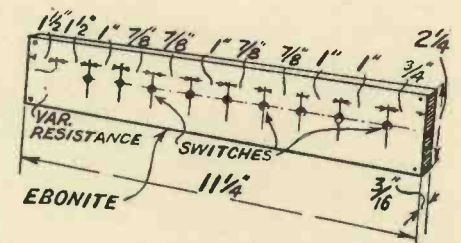
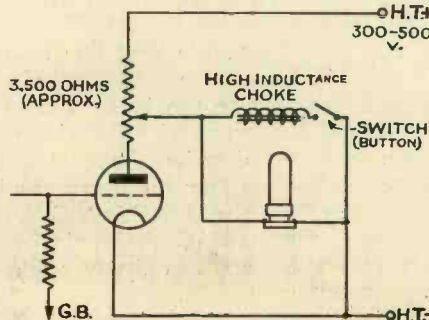

## DROITWICH AND TELEVISION

*As is well known, when the new Droitwich station takes over Daventry's service, London National*

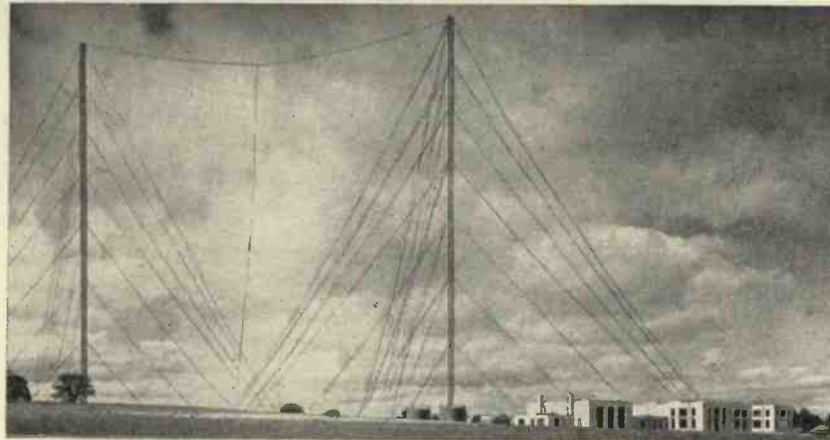

*The new giant transmitter at Droitwich.*

*will be closed down. What is to happen to the B.B.C.'s medium wave television transmissions?*

**F**EW ordinary broadcast listeners will mourn the passing of the London National station at the end of the year—but television fans are naturally anxious.

At the moment London National provides the only possible means of experimenting with medium-wave low-definition television. Meagre though the two half-hour transmissions a week obviously are, they are very much better than nothing at all.

### **Exit London National**

Lookers want to know what is going to happen to these invaluable transmissions of 30-line television when London National is shut down.

For assuredly the London National will shut down. The coming of the 150-kilowatt Droitwich giant spells the end of the road not merely for London but for North and West Nationals.

You see, none of these medium-wave stations will be needed when Droitwich is in full swing. The reliable, fade-free range of the new long-waver, which will of course replace Daventry 5XX on 1,500 metres, will be practically country-wide. It will in any case adequately serve with a National programme all listeners at present inside the 15- or 20-mile radii of the little Nationals.

From a sound broadcasting point of view there is no objection to this development. Indeed, there is everything in its favour. The release of valuable medium wavelengths will enable more regional centres to be erected. Two are already contemplated, as a matter of fact. One near Newcastle to act as a North-

Eastern Regional, another near Elgin as North Scottish Regional.

Besides, even quite close to the medium-wave Nationals, particularly the London and West—which are, you remember, synchronised on a common wavelength—reception of the National programme is exceedingly variable. During the daytime the range is limited, and at night distortion and fading are often bad enough on the fringes of the service areas concerned to make reception intolerable.

None of these drawbacks will be felt with Droitwich. Within a radius of at least 200 miles, and probably much farther than that, reception during the day or at night will be reliable—will be free from fading, distortion and, thanks to the high power, from background.

### **The Television Transmissions**

But that does not solve the looker's problem. With London National shut down what is going to happen to the medium-wave television transmissions? Quite obviously—or perhaps not so obviously—they cannot be taken over by Droitwich National on the long waves.

For one thing, the land line from Broadcasting House to Droitwich would probably be too long to carry the television image signals without very serious deterioration. Good though the lines now are between all main points in the B.B.C.'s "S.B." network, the television signals can at present be handled only over relatively short distances.

Then again, from a programme point of view the possibility of send-

ing out television from Droitwich is practically ruled out. Under the new programme plans of Broadcasting House it is proposed to send us full alternative programmes until quite late at night. Droitwich will certainly be needed every night for late dance music or other musical broadcasts.

Which leads us to ask whether, perhaps, the idea is to delegate the television transmissions to London Regional. If so, lookers will have reason not to grumble but to congratulate themselves. Because it is certainly a fact that the London Regional's reliable service area, by day and by night, is very much superior to London National.

Its higher wavelength means a bigger daylight range—and at night, because it is on this superior wavelength and not synchronised with any other B.B.C. station, it is less troubled with distortion and fading.

With London Regional it should be possible to spare at least one evening a week at, say, 11 p.m. or 11.30 p.m. In the mornings, of course, it would not be nearly so difficult to fit in a London Regional television transmission.

At the moment the B.B.C. will not commit itself to the suggestion that London Regional is to take over. Nor, for a month or so, is the matter so very urgent. It will be the end of the year before London National is shut down—three or four months being considered necessary for listeners to get thoroughly accustomed to listening to Droitwich long-waver for their National programme.

Moreover, by the end of the year the P.M.G.'s committee will no doubt have issued its findings.



A NOVEL SYSTEM

CONTINUOUS OSCILLATORY SCANNING

By Robert W. Hughes

Some preliminary details of the work of Robert W. Hughes were given last month. Here is an article by Mr. Hughes on a novel scanning system with which he is experimenting.

FOLLOWING the general practice of unidirectional scanning, very little has been mentioned about the possibilities of employing a sinusoidal movement. There can be no doubt, of course, that as a con-

might be well to say that the ratio figures given in the text are those actually used in the laboratory equipment set up for the purpose of test. Although the number of lines used was not excessive, excellent pictures

as P oscillates through a horizontal plane, it scans this false object across 120 times whilst Q, oscillating through the vertical plane, completes one half of its cycle, i.e., scans the object downwards. So for every complete picture, we have 120 horizontal lines, and with Q oscillating 10 times per second we have a picture repetition of 20 frames per second—once scanned downward, and once upward for each cycle.

The light then, from any one spot on the object, after being reflected from P to Q, and from a stationary mirror M, falls on the photo-electric cell C, the impulse fluctuations of which are amplified, and serve to modulate the light source L at the receiving end. This modulated light falls on Y, and ultimately reaches the screen I, where the image is to be reconstructed. X moves through the horizontal plane the same as P, and being driven from the same source, follows exactly the same period, and responds to the same fluctuations, if any. The same thing, of course, applies to Y, which gives the vertical movement, and the

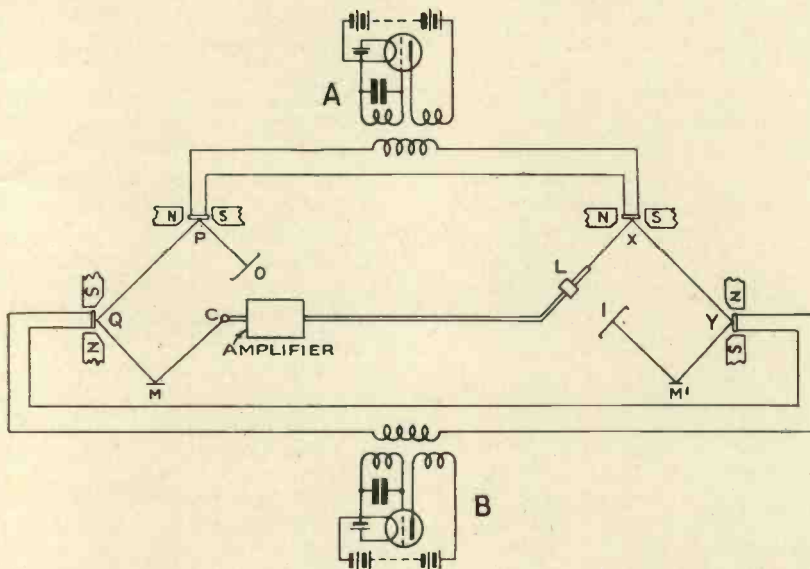

Fig. 1.—A suggested arrangement of a continuous oscillatory scanning system.

tinuous oscillatory system does not comply with present-day methods from a general broadcasting point of view, it is useless to expect anything of a revolutionary change of policy in this direction. Indeed, such a change would be grossly unjust, destroying, as it would, the years of patient labour that have been devoted to the present standard by so many brilliant workers.

There is, however, a field of scope for a foreign system in the erection of communal centres, and television theatres. Here it is not essential for the equipment to follow conventional lines, and as each link consists of comparatively few installations, compared with the ordinary broadcast to home receiver link, the problem of synchronisation may be overcome by unorthodox methods.

Fig. 1 gives a general idea of such a workable scheme in its simplest form. Before going any further, it

were obtained, detail being extraordinarily good, and movement quite clearly defined, without any appreciable edge blurr.

The apparatus, as I have stated, is diagrammatically shown in Fig. 1, shorn to the essentials for the sake of clarity. P Q and X Y are simple vibration galvanometers of the resonance type, robust, small, and very efficient. P and X are driven from the same source, the simple oscillator A, whilst Q and Y derive their movement from a similar source B. These audio-frequency oscillators are carefully constructed to give an almost perfect sine wave, and by the usual arrangement of inductance and capacity, A produces a frequency of 1,200 cycles per second, whilst B oscillates as low as 10 cycles per second. The brightly illuminated object to be scanned is conveniently reduced in size by a suitable lens system, producing an image of itself at O. Now

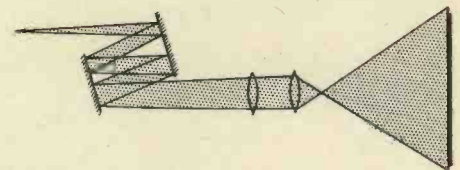

Fig. 2.—An arrangement for projecting the picture.

picture frequency. If a reasonably brilliant source is used, the picture can be truly projected by using the arrangement shown in Fig. 2. By this method, pictures approximately 3 ft. square were obtained without undue distortion or dispersion.

Both in transmitting and reconstructing, the actual scanning is taken slightly off the frame to cut out the objectionable curve of the wave form, as illustrated in Fig. 3.



So much for the laboratory equipment. Considering the practical aspect, we might suppose a ring of half a dozen theatres, or communal vision centres, each theatre equipped with its own scanning arrangement, and fed from a central agency. From

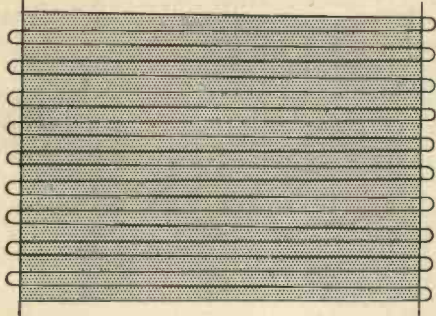

Fig. 3.—Diagram showing how the scanning is taken out of frame so that the curve of the wave form can be cut.

this agency, the synchronising impulses are conveyed by landline to each theatre, where they are suitably

amplified and led off to drive the oscillating mirrors. Framing is accomplished by merely controlling the input to each galvanometer independently, thereby causing it to vibrate more or less, covering, of course, more or less of the screen accordingly. The vision signals proper may be radiated on the ultra-short waves, or, if the theatres were conveniently situated, by special cable. Dead synchronisation is thus assured, and as the light is bunched, excellent illumination is possible. The system is equally applicable to the transmission of film, and it would be quite possible for half a dozen or more theatres to show the same film at the same time, without the trouble of rewinding spools or of losing their sound half way through, unless, of course, such a disaster occurred at the main transmitting studio.

There is no reason to suppose that 120 lines should constitute a limit. It could quite comfortably be made to operate at higher definition, and with more frames per second.

will be seen from the photograph the disc is provided with a separate spindle which runs in moulded bakelite bearings suitably bushed and mounted on a special stand.

Synchronising gear is fitted, provision being made for the support of this by an extension of one spindle bearing. The assembly of the disc and bearings is therefore a simple matter in which there can be no possibility of getting faulty alignment.

The driving motor is placed on the left of the baseboard, the drive being by an endless rubber band of circular cross section. A wooden chassis is provided and on this in addition to the motor and motor stand are mounted the bakelite neon lamp holder, terminal block, mains plug, and fixed and variable resistances.

The motor has been specially designed for the purpose and has a heavy cast aluminium frame and ball bearings. Extensions to the spindle are provided so that the motor is adaptable for other uses. Two types of motor are available, one for 6-volt battery operation and the other a universal motor suitable for running from either A.C. or D.C. mains of from 200 to 240 volts.

The scanning disc is of the conventional type, provided with eight spokes and a central eight-ribbed boss so that either the spokes or the ribs of the boss may be used as a stroboscopic indicator. The image is viewed through a large diameter single lens mounted in a U-shaped clip.

A feature of the set is the specially treated beehive type neon lamp which is provided with a mask and special reflecting surfaces to conserve the light.

### Excellent Results

A prolonged test of the motor proved that the work that it had to do was well within its capabilities, as after several hours running it was no more than appreciably warm. A reception test using the Standard Television Receiver described in the February issue of this journal showed that excellent pictures could be received with this apparatus and that the synchronising gear was effective in holding the picture steady for long periods. We have every confidence in recommending this kit receiver which represents remarkable value at the prices of 78s. for 6-volt battery operation and 84s. for either A.C. or D.C. mains.

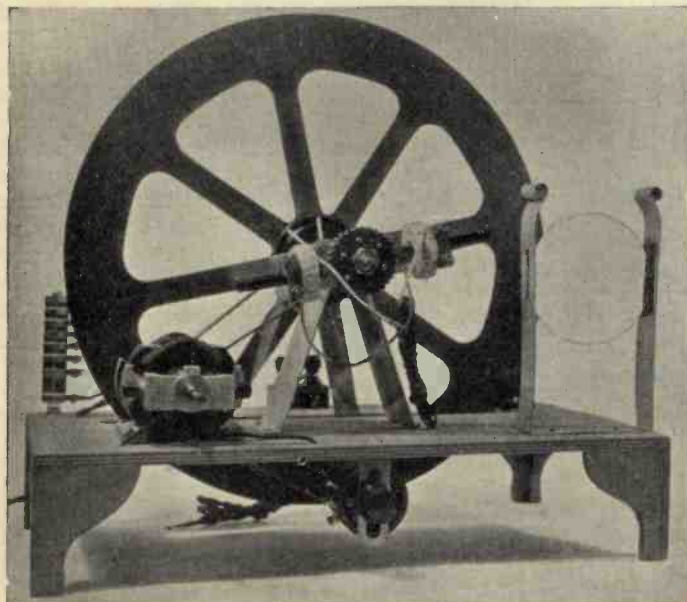

The B.T.S. disc kit assembled.

## THE B.T.S. DISC KIT

IT has been pointed out in these columns on several occasions that a certain amount of advantage was to be had by driving a scanning device indirectly. Though in this case the general layout is not quite so simple as when the disc is mounted directly on to the spindle of the driving motor, the scheme makes it possible easily to include a mechanical filter, which of course in this instance is the flexible rubber driving band;

also the drive can be geared down by the use of different sized pulleys. This latter enables the motor to be run at a more efficient speed and there is the certainty that the power requirements will be well within its capabilities.

Recognising these advantages British Television Supplies, Ltd., of Bush House, London, W.C., have placed upon the market a disc kit set incorporating these features. As



# THIS MATTER OF DEFINITION

*Last month we published an article, by Ernest Traub of the International Television Corporation, which argued that a scanning frequency of 120 lines would give results with full entertainment value. Below is an American opinion, being an extract from a paper read by William H. Wenstrom before the Institute of Radio Engineers and he defines the suitability of certain scanning frequencies according to the subject.*

**W**HAT degrees of definition (measured in lines per picture) must television attain for the suitable portrayal of various scenes under various conditions?

Four photographs were chosen to represent approximately equal gradations of scene comprehensiveness from the lowest to the highest. They were:—

noticeable; does not impair pictorial impression at all.

Good: line structure evident, impairing small details slightly.

Fair: line structure very evident, but does not impair general pictorial impression.

Poor: line structure impairs general pictorial impression.

Worthless: scene loses meaning.

for full theatre stage or outdoor spectacles.

Reversing the above order of reasoning, it is possible to determine the degree of definition required for "fair to good" rendition of various scenes:

- (a) Single face: 60-120-line.
- (b) Small group: 120-200-line.
- (c) Detached objects such as ships, aeroplanes, etc.: 120-200-line.



*Left—The definition obtainable of a single face with a scanning frequency of 120 lines. On the right is a small group, also of 120-line definition.*



1. A single face.
2. A small group (four people in three-fourths view).
3. A musical comedy stage, including three torpedo-shaped detached objects.
4. General view of a football match.

These photographs were transmitted on telephoto machines, so as to represent the performance of 60-line, 120-line, and 200-line television for each of the four scenes. Approximate representations of 400-line television were obtained by means of suitable half-to-one screens.

In studying the photographs it was found convenient to use a rating scale for television having six gradations, as follows:

Perfect: equivalent to commercial cinema; no line structure noticeable.  
Excellent line structure barely

The writer's estimate of the suitability of the several degrees of definition for the portrayal of various scenes is as follows:

(a) Sixty-line television: fair for a single face, poor for a small group or for detached objects such as a ship or aeroplane, poor to worthless for a full theatre stage or for large outdoor spectacles.

(b) One-hundred-and-twenty-line television: good for a single face, fair for a small group or detached objects, poor for full theatre stage or outdoor spectacles.

(c) Two-hundred-line television: excellent for a single face, good for small groups and detached objects, fair for full theatre stage or outdoor spectacles.

(d) Four-hundred-line television: perfect for single face, excellent for small group or detached objects, good

(e) Outdoor spectacles: 200-400-line.

From the foregoing analysis, and from observation of present television systems, certain general conclusions appear which, if verified, may have the force of basic laws governing the performance of television. These are:

(a) *The degree of definition required in any given television application is conditioned chiefly by the comprehensiveness of the scene to be portrayed.*

(b) *The higher the contrast in a given scene, the lower the order of definition required to portray it.*

(c) *While a lower order of definition may suffice for momentary presentation of certain scenes, a higher order of definition is required if the observer's continued attention is to be held.*

From these hypotheses and the

foregoing conclusions it is possible to assume certain definition requirements for the classes of television service likely to be in most demand:

- (a) Two-way telephone television: 60-120-line, fair to good.
- (b) Theatre television:
  - (1) Brief television projection of news events, faces, small groups, detached objects, etc.: 120-line, fair to good.
  - (2) Cinema projection of news events from films transmitted by telephoto methods: 120-200-line,

fog by Hammond system, etc.): 60-120-line, fair to good.

(2) Where exact size and shape of objects are important (military commander viewing battlefield, etc.): 400-800-line, fair to good.

While generalised speculations about the future of television are somewhat beyond the scope of this paper, it is interesting to examine some practical possibilities in the light of the findings above:

(a) 80-120-line two-way telephone television appears to be now techni-

equivalent to the standard cinema appears to be a practical impossibility at the present time.

(e) 120-line home television appears to be now technically possible for short range transmission, and awaiting only economic support. It is perhaps good for the sale of several million receivers and considerable advertising income.

(f) 200-400-line home television equivalent to home motion pictures would be suitable for continued universal entertainment, but appears to



*These two pictures, also of 120-line definition, are of a stage scene and a football match respectively, and they show how, when there is considerable detail, this scanning frequency is insufficient.*

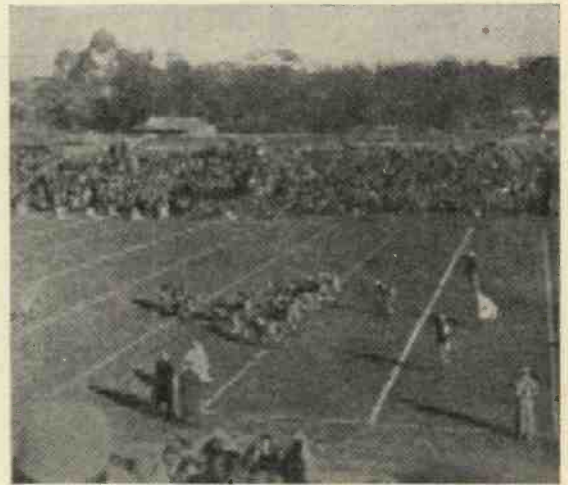

fair to excellent.

- (3) Continuous television entertainment equivalent to cinema: 400-800-line, good to excellent.
- (c) Home television, continuous:
  - (1) Faces, small groups, etc.: 120-line, fair to good.
  - (2) Full theatre stage or outdoor spectacles: 200-400-line, fair to good.
- (d) Special purpose television:
  - (1) Where contrast is high and relative position of objects is more important than their exact size or shape (pilot landing aeroplane in

cally possible, adequate for the purpose, and limited in use only by economic factors.

(b) 120-line theatre television suitable for brief news and other projections appears to be awaiting only a few electrical, optical, and mechanical refinements before it becomes technically possible.

(c) 120-200-line theatre projection of electrically transmitted news films appears to be technically possible at the present time, and adequate for the purpose.

(d) 400-800-line theatre television

be a practical impossibility for the present. It is possible that the degree of definition which home television must reach for universal commercialisation is in the neighbourhood of 200 lines.

(g) Special purpose television: for certain limited uses the 60-120-line television available at the present day is adequate; for such uses as giving a military commander a complete view of the battlefield, neither present systems, nor those to be expected in the immediate future, fulfil the requirements.

## A FAMOUS CONTRIBUTOR SPECIAL ANNOUNCEMENT

*Mr. JOHN LOGIE BAIRD, the British inventor of television, will contribute a special article in next month's issue of this journal.*

*In view of the fact that Mr. Baird so rarely can be induced to write for the press we take great pride in making this announcement.*

*We also have pleasure in announcing that members of the Baird Company's technical staff will contribute regularly in future issues of TELEVISION.*

The South African Broadcasting Company is planning television experiments somewhat in accordance with the experiments carried out by the British Broadcasting Corporation. A company has been formed, and has acquired the rights in South Africa of the most important television patents, especially those relating to cathode-ray tubes.

A new company has been formed under the style of Television Instruments, Ltd., to manufacture television components. The address is 323 City Road, London, E.C.1.



# GETTING THE BEST FROM YOUR NEON

Successful results with a television receiver depend to a very large extent on the light source, particularly with simpler types of receiver using neon lamps. The neon lamp requires operating under specific conditions if the best results are to be obtained and these are detailed in this article by J. H. Reyner, B.Sc., A.M.I.E.E.

**I**N order to obtain the best results from a neon lamp the first information we require is the characteristic of the neon lamp itself.

## Neon Characteristics

Fig. 1 gives a representative characteristic of the bee-hive type of



lamp. The normal working voltage is about 160, under which conditions the lamp takes 17 milliamps. Due to the modulation the voltage swings above or below this steady value, cause the current, and consequently the brilliancy, to vary.

The characteristic shows that if we reduce the voltage to 135 the current falls to nothing and the lamp goes out. This, of course, is the well-known characteristic of neon lamps. At the same time it limits our maximum swing to 25 volts. That is, we can swing from 160 down to 135 and up to 185.

If we exceed this voltage swing, the lamp will go out altogether and it will not light again until the voltage has reached about 160 or 170 volts. (The exact striking voltage varies slightly with different lamps.) An appreciable portion of the picture

therefore may be lost during this period when the lamp is out,

## Limited Swing

If the voltage on the lamp is not kept at 160, then the maximum swing is even more limited. At 150 volts, for instance, although the steady current is now only 10 mA, the maximum swing is only 15 volts and the maximum brilliancy of the lamp is little greater than the average brilliancy if 160 volts H.T. is used. Conversely we can get still better results by increasing the H.T. up to 170 or even more, but this begins to become very expensive in anode current.

## Applying the Voltage

The next point is to find how best to apply the necessary voltage. 25 volts maximum variation does not seem a large figure but actually if you connect a neon lamp in the anode circuit of an ordinary output valve you will experience difficulty in obtaining anything like as much as this. The reason is that the impedance of the lamp is very low. From the characteristic shown in Fig. 1, for instance, you will see that a change in voltage of 25 volts causes a change in current of approximately 17 mA. This corresponds to 1,470 ohms which is much lower than the usual load. A power valve requires an optimum load of 6,000 to 9,000 ohms as a rule and a pentode anything from 10,000 to 20,000 ohms. Consequently if a low impedance of 1,500 odd ohms is inserted direct in the anode circuit, the power developed will be quite

small and the voltage across the lamp will not build up to its proper value even when the valve is being given its full input. Moreover, with a triode output valve, very serious distortion will result.

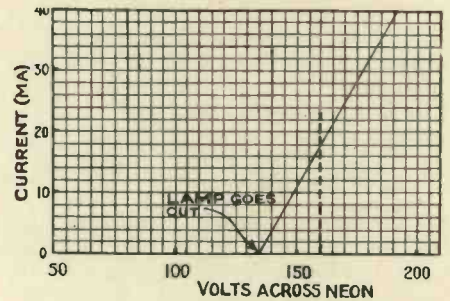

Fig. 1.—Curve showing the characteristics of a neon lamp.

The remedy is to use a correctly-designed output transformer. A 2.7 to 1 ratio for example, would convert this impedance of 1,470 ohms into 10,750 ohms on the primary which is a more reasonable value. It would,

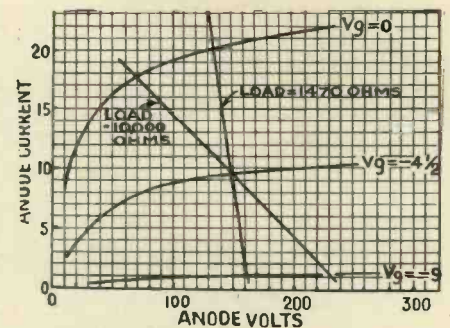

Fig. 2.—Characteristics of the PM 22A.

in fact, be acceptable to most triodes and pentodes and despite the step-down ratio there would be little difficulty in obtaining the necessary voltage swing.

Fig. 2, for instance, shows a typical low-consumption output pentode operating with 150 volts H.T., 4½ volts grid bias and a load of 10,000 ohms. The anode swing will be seen

## NEXT MONTH

A SPECIAL CONTRIBUTION

BY

Mr. J. L. BAIRD



## WORKING THE NEON FROM BATTERIES

to be approximately 80 volts peak and this divided by 2.7 gives 29.6 volts, i.e., comfortably in excess of the 25 volts required to load the neon lamp fully.

As a matter of interest the load line for 1,470 ohms has also been drawn and it will be seen that the anode swing is only 15 volts peak even with the valve fully loaded. Incidentally with proper conditions, the power consumed is not excessive, being actually  $25 \times 17/2 = 212$  milliwatts, a figure well within the capacity of the normal battery output pentode. Remember, however, that the output transformer must have a good response at the upper and lower ends of the frequency scale—more so than for ordinary music.

### Synchronising

No mention has been made so far of the question of synchronisation. We have considered only the lamp providing the illumination. In many cases the synchronising coils are included in series with the output. This is definitely bad, particularly if the same haphazard methods are adopted.

Many television receivers are mains driven and will supply much more than the 200 odd milliwatts necessary to drive the lamp, but the synchronising power required is much more than many people realise. I carried out some experiments on this point on two receivers. The first of these was provided with a Baird motor and a Baird synchroniser. The teeth were set so that the pole pieces were one-third of the way between two consecutive teeth, as shown in Fig. 3. The voltage was applied across the synchronising coils until the magnetic force was sufficient to pull the wheel round so that the pole pieces were in line with the teeth. It required a voltage of 136 and a current of 45 mA corresponding to 6.1 watts.

A similar test on a B.T.S. kit with B.T.S. synchronising gear required 83 volts at 55 milliamps, corresponding to  $4\frac{1}{2}$  watts.

Now this test is perhaps a little severe because the synchronising pull is not really required until the pole pieces are nearly in line, assuming that the machine is in synchronism. If the machine is not in synchronism, however, it is quite possible for the pole pieces to be out of line to the extent of one-third of the picture. It

is, in fact, just at such moments that one requires the full operation of the synchronising pulse and, as we see, this requires from 4 to 6 watts.

It is obvious, therefore, that the functions of the synchronising and the modulation should be separated and each should be designed to operate under optimum conditions. Since

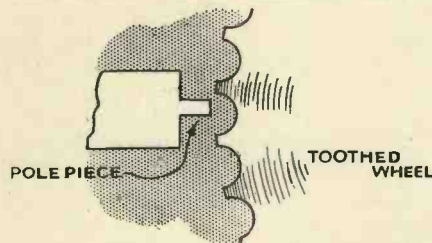

Fig. 3.—Relative positions of toothed wheel and pole piece during synchronising test.

distortion is not of serious consequence it is possible to operate the synchronising valve under conditions of maximum power output in which case it will give something approaching twice the normal rate of undistorted power output, so that the watts required can be achieved with ordinary output valves with a little care.

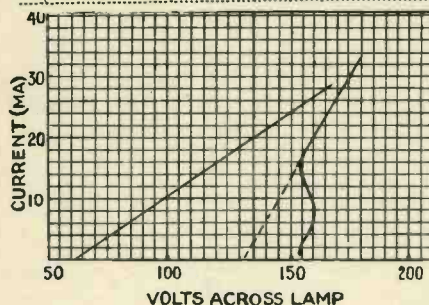

Fig. 4.—Some lamps have an unstable characteristic, as shown here.

### Battery Operation

For battery work it seems that some special technique would be required and I hope to say more about this on a future occasion, but it is obviously desirable to feed the neon from its own output valve as already described leaving the synchronism to be obtained from a separate valve.

Generally speaking a voltage of about 160 is suitable for battery operation. This gives a reasonably brilliant picture, without taking too much from the battery. Use a super-capacity battery which will stand up to a steady drain of 15 to 20 mA.

Reverting to the question of the modulation, although the neon lamp can be caused to modulate fully with a relatively small power, it will be obvious at once that the characteristic of the average lamp is far from ideal. At the present moment if we want to increase the range of modulation the only method is to increase the high-tension voltage and with it the steady anode current which begins to become an expensive matter unless one is running off the mains.

Even here care must be taken to ensure a good regulation. With the ordinary mains supply system, the voltage falls off quite appreciably as the current increases and this tends to limit the modulation but, for all that, a marked improvement could be obtained by running the lamp at a voltage of, say, 200, and feeding it with a peak modulation voltage of 65.

The ultimate limitation in this method lies in the steady wattage-dissipation. Under the conditions at first specified (160 volts and 17 milliamps.) the standing dissipation is 2.71 watts. With 200 volts H.T. the watts dissipation goes up to 9.1 which is probably more than the lamp will stand for any length of time.

As explained at the beginning of the article, the characteristic, shown in Fig. 1, is a representative one taken as an average of a number of lamps. During these tests, however, one or two lamps were found which were quite unsuitable for the purpose. They did not exhibit a straight and nicely-behaved characteristic at all, but showed a form of instability. As the voltage was reduced from the striking point, the lamp flickered and went out long before the normal extinction point was reached.

The actual characteristic was found to be of the form shown in Fig. 4 and this will clearly be seen to be unsuitable for television. After running the lamp for a period of about half-an-hour, the characteristic became somewhat more stable and the lamp could be used, but the fact that such instability can exist shows the desirability of checking the lamp which is being used or alternatively purchasing lamps which have been specially checked as suitable for television.



# LOEWE TELEVISION DEMONSTRATED IN LONDON



*A large van equipped with the Loewe transmitting and receiving apparatus was brought to London for the purpose of the demonstration. Transmission was made upon 7 metres to a receiver in the annexe of the Polytechnic.*

**R**ECENTLY a travelling television transmitter demonstrated Loewe television on suitable receivers inside the Polytechnic annexe. The entire equipment was contained in a magnificent stream-lined van about thirty feet long, finished in bright blue, with chromium-plated lettering. This unit was brought over from Germany by the Loewe Company for demonstration purposes and comprised a complete television and sound transmitting equipment.

The television transmitter was of the conventional film type with sound head attachment for reproducing the accompanying speech or music. Continuously moving film was used in conjunction with a 90-hole scanning disc running at 3,000 revolutions per minute, thus producing 180-line images.

The currents generated by the photo-cell were amplified by a special

four-stage amplifier of exceedingly compact design.

Various auxiliary electrical gear was mounted inside the van such as a mains supply unit for the amplifiers, a special amplifier for generat-

---

*In view of the many reports of the progress of television in Germany, the following eye-witness account of a demonstration of the Loewe system which was recently made in London is of particular interest. The apparatus which was demonstrated had been designed for the standard German 180-line 25 pictures per second transmissions.*

---

ing synchronising impulses, a sound amplifier, and a small cathode-ray oscillograph permanently connected with the amplifier circuits, which enables the transmitting engineer to check up the potentials, and to judge

the quality of the transmission by the thickness of the line produced with the cathode-ray oscillograph.

Following the amplifiers were two ultra-short-wave transmitters, one for sound and one for vision. These transmitters were again exceedingly compact and beautifully designed, each of them being no bigger than an ordinary three-valve set. The output from each transmitter was three watts, and they were fitted to separate half-wave aerials on the roof of the van.

Electrical supply was taken from a long cable connected to the local alternating current mains.

In a separate compartment of the van was a generator converting A.C. into D.C. for the operation of the arc-lamp used for the transmitter.

Inside the building was the latest Loewe cathode-ray receiver for 180 lines. This receiver was quite a compact job considering the intricate apparatus it contained.

The picture size at the end of the tube is roughly 5½ in. by 6½ in. The receiver contains the tube, a mains unit for feeding it, the time base, and a combined sound and vision radio receiver.

This receiving system is the invention of Dr. Schlesinger, the chief television engineer of the Loewe Company.

The sound and vision programmes were transmitted on neighbouring wavelengths. On the receiver these two carriers were picked up by a common aerial circuit, and amplified by the common high-frequency stage and then detected and filtered separately.

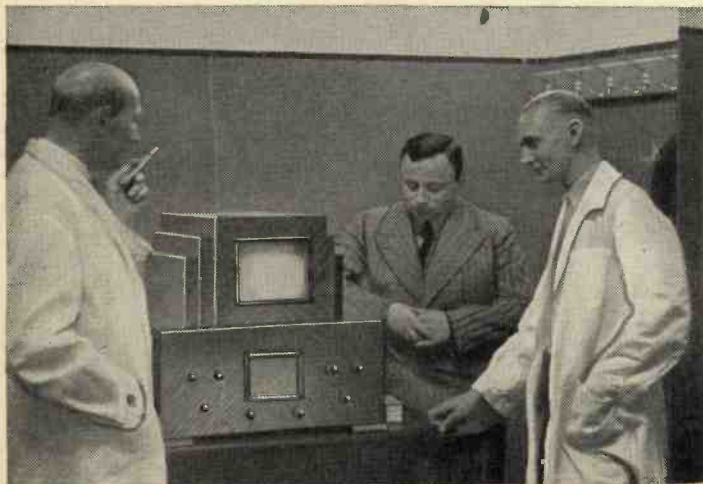

*Dr. Loewe and Dr. Schlesinger are seen in this picture with the Loewe receiver.*

The great advantage of the system is that only one tuning control is necessary on the receiver to tune in simultaneously to sound and vision programmes. If there were several sound and vision programmes on the air there could be no possibility of receiving a picture with the wrong sound accompaniment.

A feature of this system is that, by turning the tuning control a little to one side of the carrier, sound can be received without the picture, and by turning to the other side of the carrier a silent picture is received.

The advantages and simplification due to such a system are, of course, enormous. The radio receiver is a six-valve super-het. Ten radio valves are used in all in the receiver, and three rectifying valves.

The 180-line images were remarkable in their detail and gradation of contrast.

"Our aim has been to produce an apparatus that could be marketed at a price the public could afford to pay," explained Dr. Loewe. He added that work had been done to make the apparatus suitable for the standard 180-line 25-pictures per second transmissions put out by the German Post Office below 10 metres.

"We do not claim to have invented an entirely unique system," admitted

Dr. Loewe, "but we do think that we have reached a stage of commercial production that is in advance of most people."

If his claims are true, he certainly has advanced. There is no doubt about the entertainment value of the pictures. If these can be had in the home for the price quoted—300 marks



*A view of the Loewe 180-line television receiver which it is stated could be marketed for about £30.*

ex-works—then the Doctor may well be pleased with himself, especially as the cathode-ray tube used in the system can, he says, be marketed on a mass-production basis for as little as £4, with a life of at least 1,000 hours and sometimes much longer.

The cathode-ray tube actually used at the time had a diameter of 25 centimetres, and there is a larger one of 35 centimetres. Taking the picture as the inscribed square of the smaller tube, and enlarging it up to the permissible limit by means of a lens, the resulting picture is 15 cm. by 18 cm., or with the bigger tube 18 cm. by 24 cm.

It is claimed that extra tubes can easily be fitted by extension leads to the main set, so that pictures might be looked at in several different rooms at the same time off the one set. Just like adding extension loud-speakers!

It is understood that the Loewe firm considers it has solved the problem of television in the home—but is now waiting for transmissions to justify mass production of the apparatus.

The difficulties of the ultra-short-wave technique seem to have been solved by the German engineers.

It was stated that the whole apparatus takes only 150 watts from the mains.

If the apparatus can really be marketed as cheaply as Dr. Loewe states, and granted regular transmissions from the Post Office station on 7 metres, there seems little doubt but that in Germany at least popular television will be available before the end of the year.

## NEW AMERICAN TRANSMISSIONS

AMERICA's newest television company to announce operations is the National Television Corp. of New York. This new concern will transmit programmes as well as sell receiving sets. The results of more than two years' intensive research will be demonstrated when the new company begins commercial operations, probably in September.

This new firm is a subsidiary of the Sirian Lamp Co., which is also affiliated with other manufacturing companies, including Arcturus Radio Tube Co. and World Bestos Corporation. Both actual performers in the "flesh" and films will be televised.

Mechanical scanning with a 60-line mirror-drum will be used. Later it is expected to advance to 120 lines.

The company intends putting a re-

ceiving set on the market. In general appearance it resembles a modernistic American receiving set, but the image, instead of being seen in the centre of the set, is focused on the corner. This, it is contended, enables a comparatively large audience to see the pictures. Pictures are approximately 6 inches square. The price will be about \$200.00. Plans are now being made for the entertainment to be furnished.

## BRITISH TELEVISION SUPPLIES

A new company marketing television kits and apparatus has been formed, with headquarters at Bush House, London, W.C.2, with the name British Television Supplies, Ltd. Television apparatus already in production includes the B.T.S. indirect drive television disc receiver for home assembly, retailing at 84s. for A.C. or D.C. mains, and at 78s.

for 6-volt battery operation. B.T.S. apparatus can be obtained from any first-class radio factor.

## A USEFUL VALVE GUIDE

We have received a copy of the 1934-5 Osram valve guide published by the General Electric Co., Ltd.

In view of the rapidly multiplying number of valve types a reference booklet providing complete technical information and working data for each type, and yet retaining a handy pocket size is most useful.

In addition to the data charts, the Osram valve guide contains much helpful information, circuit diagrams, and useful description of the application of modern valves. A copy can be had on application to the General Electric Co., Ltd., Magnet House, Kingsway, W.C.2, upon mention of TELEVISION.



# RECENT DEVELOPMENTS

## A RECORD OF PATENTS AND PROGRESS Specially Compiled for this Journal

### "Film" Systems (Patent No. 409,400.)

In the present state of the art, the transmission of sporting events, or of outdoor scenes in general, is difficult with the usual type of scanning apparatus, particularly in dull weather. One method of overcoming the difficulty is to record the scene on a moving-picture camera, the film being passed immediately afterwards through a scanning-device which feeds the resulting signal to a local transmitter. The present invention discloses means for speeding-up this procedure so as to get the signals into the ether with the least possible delay. With this object in view, the film is subjected to the scanning-device after a preliminary development limited to an immersion for two seconds in a strongly-alkaline solution. The final fixing, washing, and drying is completed, if necessary, after the film has been televised. The photographic coating used on the film is preferably "blue sensitive," and a red source of light is used for the scanning operation.—(*Fernseh. Akt.*)

### Scanning Discs (Patent No. 410,023.)

In a scanning disc of the "spider" type, in which the rim is connected to the boss by spokes, the latter are subjected to strains which tend to shear them through, particularly when the disc is being started up. It has been discovered that this undesirable stress can be minimised by forming the spokes so that, instead of being radial, they slope forward, in the direction of rotation. A double-webbed spoke is also described which is stated to have the same advantage, no matter in which direction the disc is rotated.—(*Fernseh. Akt.*)

### Synchronising Apparatus (Patent No. 410,678.)

In general, it is necessary to "frame" the received picture accurately on the viewing-screen by hand control, though it is possible to assist matters by sending-out a rhythmic "framing" signal from the trans-

mitter. It is now proposed to further simplify the operation by utilising the framing signal to block-out the normal action of the synchronis-

strip, and if the picture is in correct phase a series of pulses are sent into the tuned circuit L, which removes the space charge on the detector D

*A television system in which the framing signal is utilised to render the normal synchronising apparatus inoperative until the receiving apparatus attains its correct phase. Patent No. 410678.*

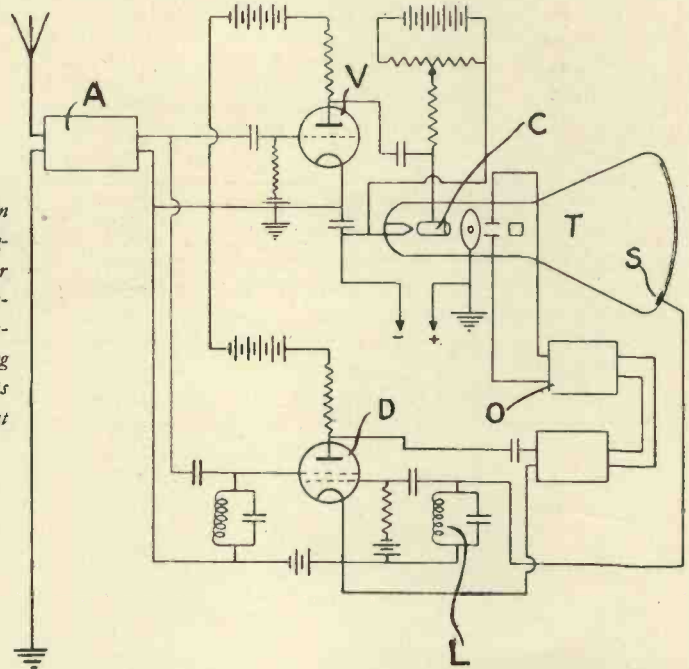

ing-electrodes until such time as the picture automatically "drifts" into correct phase. The normal synchronising action is then restored to lock the picture in position. At the transmitting end, a commutator on the shaft of the motor driving the scanning-disc sends out a framing signal during the time corresponding to the interval between the end of one line of scanning and the beginning of the next.

The figure shows the arrangement at the receiving end. The incoming signals are amplified at A, and are then divided between (a) the valve V which feeds them to the Wehnelt cylinder C of the cathode-ray tube T, and (b) an anode-bend detector D the space-charge grid of which is connected to a special conducting strip S separated from the lower part of the fluorescent screen in the tube. As each scanning operation is completed, the cathode-ray passes on to this

and so allows the saw-tooth generator O to lock the picture in position. If, however, the picture signals are not in phase, the detector D "blocks" the saw-tooth generator O, and the synchronising frequencies are withheld until the picture gradually drifts into correct framing, whereupon the synchronising frequencies are applied to hold it there.—(*J. C. Wilson and Baird Television, Ltd.*)

### Cathode-Ray Tubes (Patent No. 411,120.)

The object of this invention is to improve the focusing of the beam in a cathode-ray tube. In practice the end of the cathode from which the emission starts, although small in area is yet larger than the theoretical "point" required to obtain a clear-cut focusing of the beam on the fluorescent screen. To overcome this drawback the electrode assembly is designed so that the distance between

The information and illustrations on this page are given with permission of the Controller of H.M. Stationery Office.

the spot O of electron-emitting oxide and the aperture O<sub>1</sub> in the Wehnelt cylinder C is less than half the diameter of the latter.—(Telefunken Co.)

### Centring the Beam

(Patent No. 411,411.)

In assembling the electrodes of a cathode-ray tube, it is essential for the cathode C to be accurately cen-

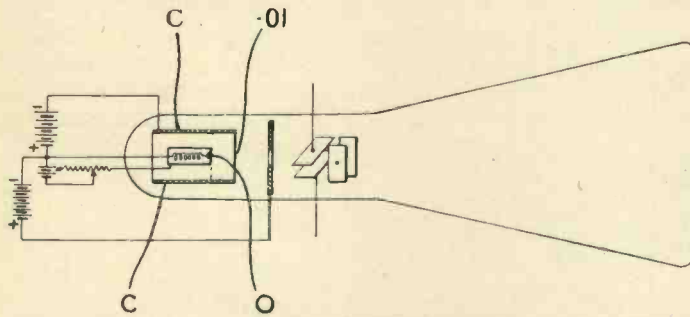

Cathode-ray tube in which emission takes place from a concentrated area. Patent No. 411120.

tered, relatively to the aperture O in the anode A; otherwise the ray will not pass cleanly through the aperture and some of the energy will be lost. This difficulty is overcome by mounting the cathode upon a "springy" support, such as the corrugated glass tube T, so that it can be given a slight displacement to one side or other (after it is first inserted in posi-

tion) by means of the protruding glass stem S. Once it has been accurately centred, the space around the tube T is filled with a suitable liquid cement, which sets hard and locks the whole assembly firmly in position.—(Telefunken Co.)

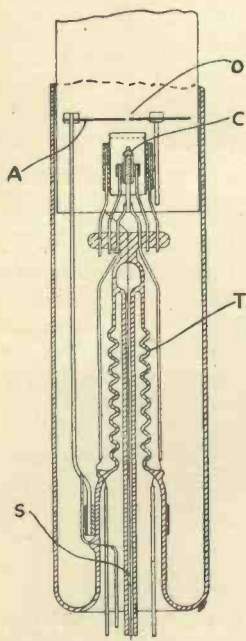

A cathode-ray tube with the electrode system supported by a flexible member which can flex to enable the electrode system to be adjusted for accurate centring. Patent No. 411411.

tion) by means of the protruding glass stem S. Once it has been accurately centred, the space around the tube T is filled with a suitable liquid cement, which sets hard and locks the whole assembly firmly in position.—(Telefunken Co.)

### "Screen" Television

(Patent No. 411,835.)

This invention relates to a system for producing moving-picture effects on a viewing-screen built up of a large number of closely-set incandescent lamps. The lamps are wired up to a similar bank or screen of selenium cells situated at some dis-

tant place. The picture or event to be televised is focused on to the bank of photo-sensitive cells, and the resultant currents are then fed to relays which control the lighting of the various lamps on the viewing screen. In this way the light-and-shade effects of the original picture are reproduced from a distance. Usually it is necessary to utilise relays of a highly-sensitive type since the output current from each of the selenium cells is small. The inventor overcomes this difficulty by using grid-glow valves of the Thyatron type as a coupling between the cells and the lamps in order to "trigger" the latter into action as the picture changes.—(H. Rosenberg.)

### Intensity Modulation

(Patent No. 411,883.)

One way of controlling or modulat-

ing the electron stream in a cathode-ray receiver is to subject it to the action of an electrostatic field set up by the received signal across a pair of condenser electrodes. In other cases the signal currents are applied to a pair of coils, so that the control

is magnetic instead of electrostatic. The present arrangement makes use of a magnetic field produced by the incoming signals to vary the "intensity" of the stream before it reaches the fluorescent screen. In order to make the control as effective as possible, the coil C carrying the signal currents is wound closely around a narrow tube A which acts as an anode and carries the stream from the cathode K to the viewing screen S. As will be seen from the drawing, the tube is made in two separate parts, one containing the cathode K, and the other the viewing screen S. Both parts are hermetically sealed off around the tube A which forms the only connection between them.—(International General Electric Co.)

### Summary of Other Patents

(Patent No. 410,478.)

Method of applying control voltages to the electrodes of a cathode-ray tube.—(Electric and Musical Industries and J. D. McGee.)

(Patent No. 410,546.)

Improvements in electro-optical light-valve assemblies.—(W. W. Jacomb, T. W. Collier and Baird Television, Ltd.)

(Patent No. 410,966.)

Design of scanning device comprising two rotating mirrors with an interposed reflecting prism.—(H. Pabst.)

(Patent No. 411,002.)

Photo-electric cells of the alkali-metal type in which means are employed to remove undesired traces of hydrogen and other gases.—(N. V. Philips Co.)

(Patent No. 411,489.)

Improvements in the arrangement of lens drums used for television scan-

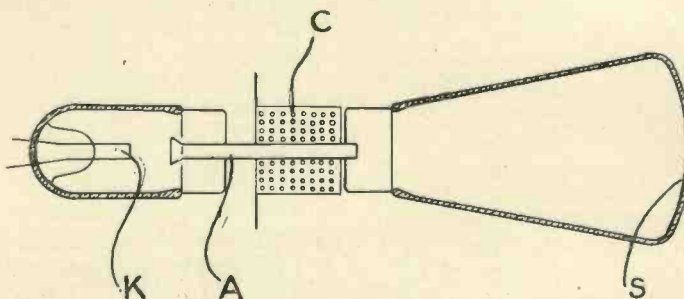

Cathode-ray tube in which the intensity of the ray is modulated magnetically.

ning.—(Marconi's Wireless Telegraph Co., Ltd., and H. M. Dowsett.) (Patent No. 411,490.)

Construction of Kerr cell with gold-plated mica electrodes.—(Marconi's Wireless Telegraph Co., Ltd., and G. F. Brett.)



# A STANDARD LIGHT SOURCE

## FOR THE AMATEUR By ROBERT DESMOND

*A standard light source is one of the first requirements of a television experimenter who takes any practical interest in the production of his own television signals using any system requiring a photo-cell.*

**O**BVIOUSLY different sources of light give out different amounts of light. Most of us vaguely know that the illuminating power of a given source of light is generally referred to, as so many candle power or c.p. In this country the standard amount of illumination known as a candle-power is the amount of light given off by a standard spermaceti candle weighing six to the pound and burn-

tensity produced on an object one foot from a source of one candle power.

### The Unit of Light

In the literature of television the unit of light which one generally comes across is the lumen, which is the unit of radiated luminous energy, or very simply—unit quantity of light. If a source of light of one candle power be placed in the centre

to obtain at will the same amount of light, whether it be one or a hundred lumens, though of course one must know within fairly reasonable accuracy to what the value of one's own standard corresponds.

### The Standard Lamp

Of the various sources of light, the amateur has really only one which can

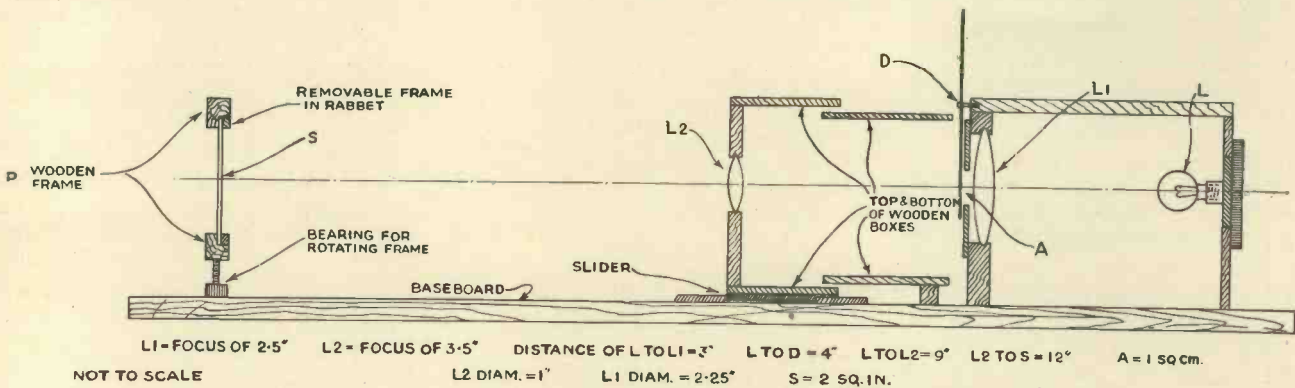

Fig. 1.—Diagram showing the optical arrangements of the standard light source apparatus.

ing at the rate of two grains per minute.

### How Light is Measured

Now supposing we had a light source of 10 c.p. If we placed it one foot from a screen it would throw upon the screen ten times as much light as a standard candle would placed the same distance away. Move the 10 c.p. light source away from the screen and the screen will be less brilliantly illuminated while at four feet our 10 c.p. light source will illuminate the screen less brightly than the candle one foot away. We must distinguish, therefore, between illuminating power of a source of light and the intensity of illumination which it produces.

The unit of intensity of illumination is the foot-candle and is the in-

of a sphere of one foot radius the amount of light falling on one square foot of the surface of the sphere is one lumen, thus 1 c.p. equals  $4\pi$  lumens. Such, briefly are the standard units of light, which to obtain exactly is rather beyond the average means of the amateur experimenter, nor is it hardly necessary to be able to produce the exact units. What is necessary, however, is to be able

be used as a standard—the electric filament lamp. Any metal filament lamp may be used provided it is run at a constant voltage. It appears preferable to run the lamp at about 15 per cent. below its rated voltage. Firstly the lamp will have a longer life and secondly the light output will vary less for any small changes of the applied volts. The fact that constant volts have to be applied makes

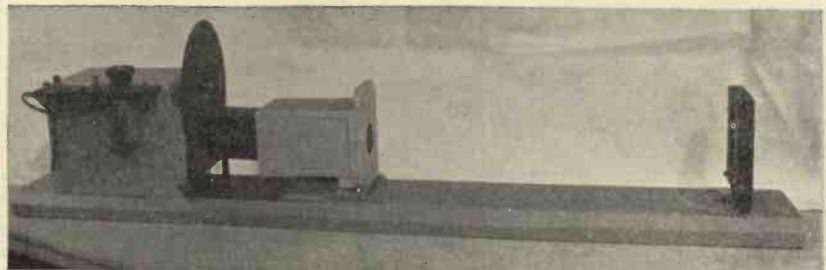

Fig. 2.—This photograph shows the complete experimental apparatus.

it definitely undesirable to use public mains. Undoubtedly an accumulator battery is the best source to run any standard light source from, and it will be generally found more con-

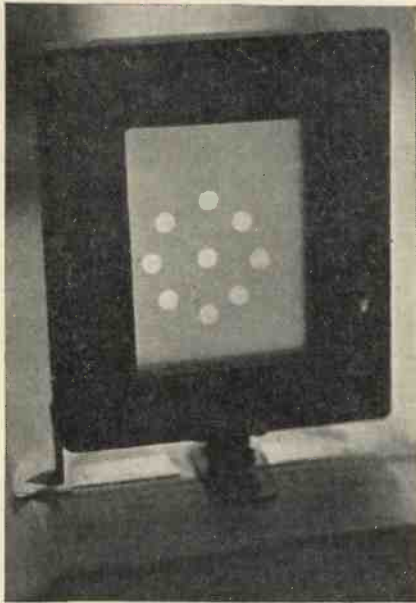

Fig. 3.—A photograph of the diffusing screen showing the nine projected light spots.

venient to use low-voltage bulbs, especially as suitable controlling rheostats are easier to obtain.

The simplest form of standard light source is an electric light bulb run at a definite predetermined voltage, the photo-cells which are to be tested being always placed at some fixed distance from the lamp. A refinement, which would probably be essential, would be to put the lamp in some sort of box with an opening so that the light would be only directed in one direction, the advantage being, that the surrounding objects, being moved or different from time to time, would be less likely to cause errors from the different value of reflected light from the general surroundings. Another refinement would be to make the opening in the box variable in size so as to let out more or less light as required. The standard light source to be described is, however, somewhat more complicated.

The actual source of light is an ordinary 3.5-volt screw bulb. Turning to Fig. 1, the light from the lamp L is collected by a simple lens L<sub>1</sub> acting as a condenser, which evenly illuminates a square aperture at A. The lens L<sub>2</sub> projects the image of the aperture A on to a diffusing screen of opal or ground glass S, while the photo-cell under test is

placed on the opposite side at P. D is a metal disc which when revolved passes ten groups of smaller apertures in front of the fixed square one A. The lens L<sub>2</sub> is movable so as to allow the image of the aperture to be focused other than on the screen S which is made removable.

## Construction

Fig. 2 is a photograph of the completed apparatus which clearly shows the wooden lamphouse mounted on the baseboard, the metal aperture disc, the projecting lens support attached to metal sliders and the two plywood boxes, one of which is fixed to the movable lens support the other mounted on a wooden post. These two boxes slide into each other and take the place of bellows. At the other end to the lamphouse is the wooden frame in which the ground glass for diffusing purposes is fitted. This wooden frame is fitted with a removable frame so as to allow the ground glass to be removed and re-

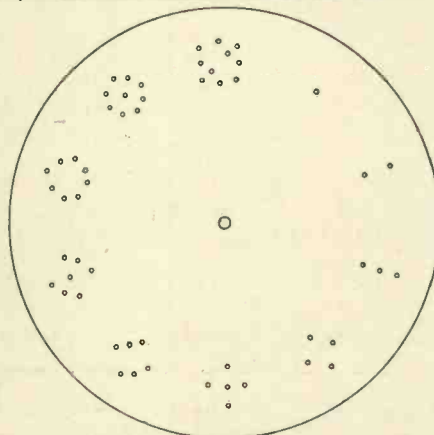

Fig. 4.—Details of the perforated disc.

placed with other materials. The whole frame can be rotated, the centre bearing being made from Meccano parts. A metal protractor is fixed to the baseboard and a pointer is attached to the side of the frame, so that the frame, when rotated, is revolved through a number of degrees. The controlling rheostat, etc., can also be seen. Fig. 3 is a photograph of the diffusing screen and frame upon which are nine spots of light projected from the metal aperture disc. This disc is shown in detail in Fig. 4. It is for the purpose of producing ten different quantities of light, which with the square aperture gives us eleven different light values. The ten different values given by the rotating disc from one to ten are

arbitrary values of lumens. The disc which is of aluminium was drilled with .05 inch diameter drill to make the apertures, care being taken to drill the cleanest holes possible. The lantern box is made of plywood, there being no danger from the lamp of over-heating it. Fig. 5 is a close up view of the lantern box with the bulb and its fixings removed from the box and put on top so as to show the construction. The lampholder is mounted on two plywood circles, fastened together, the smaller of which has been cut from the back of the lantern box. Two lips of strip brass are attached to the smaller circle of wood for the purpose of keeping the lamp in position. The opening at the back of the lamphouse has a notch cut away so that one simply has to hinge in the lamp mounting, making sure that one of the lips is opposite this notch, and when the lamp is pushed home, a slight turn locks the lamp in position. On the side of the lantern box is a strip of ebonite, fixed by two small metal brackets, on which is mounted an old compression type of rheostat, two terminals and two sockets for wander plugs. A 4-volt supply is brought to the terminals which feed the lamp via the rheostat, two sockets being connected across the lamp for the purpose of attaching a voltmeter. The aperture disc can also be clearly seen in Fig. 5.

With regard to the actual screw bulb itself it was considered wiser to

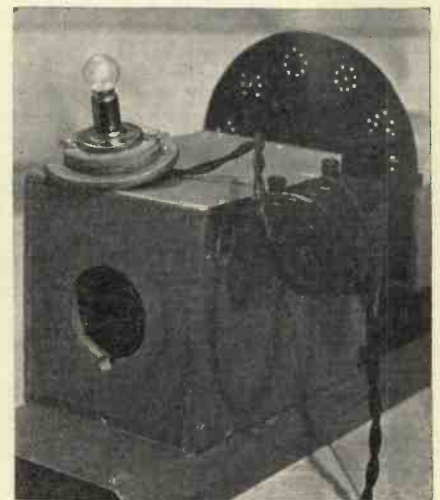

Fig. 5.—A close-up of one end of the apparatus showing the lamp house. (The lamp is removed.)

age it somewhat. Accordingly six lamps were obtained, three British and three very cheap foreign ones, and all six lamps after testing them

(Continued at foot of page 398.)



# MODULATING THE ARC

By G. B. Banks, B.Sc., and J. C. Wilson  
of Baird Television Ltd.

*Very little information has hitherto been published on the modulation of the arc light for television, and this article therefore, by two research engineers of the Baird Co., will be of particular value to those who are experimenting with different light sources.*

OF the various forms of modulated light source for use with television scanning devices for reception, probably most are by now thoroughly familiar to the majority of readers: the gas-discharge tube (of which perhaps the most useful form is the negative-glow, or flat-plate neon), the electro-optically controlled light source (such as the Kerr and Faraday cells, with polarising devices), and the electron-beam-excited fluorescent screen (as used in cathode ray tubes). There is, however, another form of light source capable of direct modulation in intensity in accordance with television signals about which very little technical information has hitherto been published. This is the directly-modulated high-intensity arc, the utility of which for television purposes was demonstrated at the last meeting of the British Association in London by Baird Television, Ltd.

Although this form of arc had not previously been used for television purposes in this country, its properties and susceptibility of modulation were quite well known many years ago. In 1904, for instance, in his book "Alternating- and Direct-cur-

rency of 50 to 4,000 cycles per second. The sound became inaudible only when the frequency was raised to 30,000 cycles per second."

Simon measured the order of magnitude of the current impulses in the modulated arc also, and came to the conclusion, based on certain assumptions regarding the constants of the gases of the arc-flame, that the kind of temperature variation produced by a current impulse was about  $0.3^{\circ}$  C., and from this calculated the order of density variation too. Braun had previously predicted that the efficiency of the modulated arc would increase with increase in total current (Weid. Ann., 65, p. 358, 1898), and in the first year of the twentieth century, Simon verified this.

The experiments of Ernest Ruhmer, using arcs the light of which was

directly modulated by telephone currents in order to transmit speech over a light-beam with a selenium cell as the responsive element at the distant end, seems to have been the first use made of the luminous properties of the "speaking arc." Bernouchi followed this up by transmitting photo-telegraphic signals over a beam of light with a directly-modulated arc (see "Practical Television," Lerner, pp. 44-45), but the first time the "speaking-arc" was proposed as a television light source was in 1921, when E. W. Whiston filed his application for British Patent No. 185,463. This was closely followed up by J. L. Baird, who, in his Patent No. 269,219, described an improved modification of the modulated arc, which was very much more sensitive to modulation.

## Special Electrodes

The modern modulated arc for television purposes, however, has evolved considerably from these early beginnings; the light-variations are found to depend upon the luminosity of the gaseous envelope partly surrounding and partly within

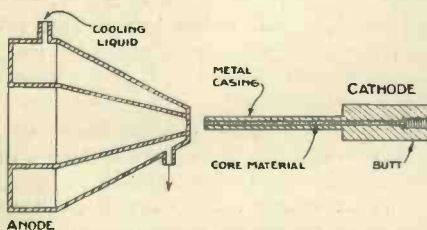

Fig. 1. A diagram of a special electrode for the television arc developed by Baird Television Ltd.

rent Electric Arcs," Monasch says, regarding the modulated arc for "speaking-arc" purposes:

"With a 10-ampere direct current arc of between 3 and 5 millimetres, between either solid or cored carbons, a clearly audible sound was produced even when an alternating current of one milliampere was superimposed on the direct current, and having a period-



The Fernseh A.G. 180-line cathode-ray receiver, a new German apparatus which is reported to give very fine results.

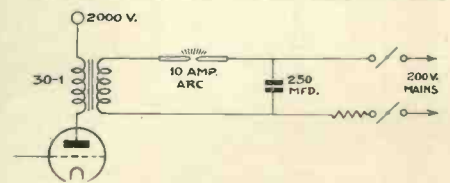

Fig. 2. The type of circuit used to supply the arc with striking current upon which are imposed the television signals.

the crater of the negative electrode. This discovery led to the construction of arc-electrodes made of metal, which more quickly conduct away the heat from the electrode-tips, and leave the gases free to contribute the major portion of the light from the arc; this greatly increased the "saturation" or contrast of the television picture reproduced. At the same time, the negative elec-

trode was cored with refractory material, such as oxide of cerium and other salts of the metals of the alkaline earths, to increase the brightness and improve the colour of the light given out by the flame of the arc.

Owing to the very great intrinsic brilliance of the crater and hot gases of the arc, and to the fact that no auxiliary light-absorbing devices, such as prisms or cells of liquid, are required, the picture produced by means of the directly modulated arc

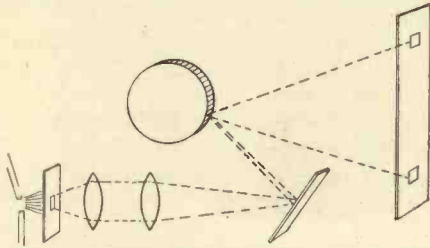

Fig. 3. Arrangement of the optical system using a modulated arc and mirror-drum scanner.

can be projected to a very large size, and pictures three feet by seven feet have actually been thrown upon a demonstration screen by this method.

Fig. 1 is a diagram of a special form of electrode for the modulated television arc which has been de-

veloped in the laboratories of Baird Television, Ltd., and is described in their Patent No. 380,109. The shaft of the negative electrode is made of copper, and is provided with a heavy butt at the end, to carry off heat quickly by conduction.

Fig. 2 shows the kind of circuit used to supply the arc with striking current, upon which are superimposed the variations due to the incoming television signal.

## Optical Arrangements for the Modulated Arc

Details of an optical system, comprising a pair of separated lenses, for overcoming the variation in screen brightness which would otherwise accompany slight lateral movements of the flame of the arc (due to slight inhomogeneities in the cerium coring of the negative electrode) are given in Fig. 3; further details of this are given in the specification of Patent No. 380,234 (Baird Television, Ltd., and G. B. Banks).

In order fully to modulate the arc, considerable power is necessary: theoretically, for maximum modulation, the A.C. input would have to be half the D.C. power of the arc, but in practice considerably less is

found to be necessary. For an arc passing 10 amperes, representing about 300 watts (see the curve given in Fig. 4) it is necessary therefore to provide an output stage to the amplifier capable of delivering over 100 watts of undistorted power. An M 25 B modulating valve will give this output comfortably. In operation, the high-power modulated arc yields a measured frequency-response, obtained with a photocell and

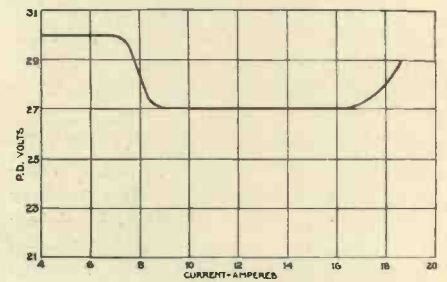

Fig. 4. Curve showing characteristics of modulated arc.

valve voltmeter, which is practically level from 10 to 35,000 cycles; only a small portion of the flame, however, at the brightest part of the arc, is effectively modulated, and this portion is situated very close to the negative electrode.

## A Standard Light Source for the Amateur

(Continued from page 396.)

on a photo-cell photometer, were run for 182 hours continuously with a voltage of 3.2 across the filaments, the lamps being rated at 3.5 volts. They were then all checked by the photometer and appeared to have all dropped about 7 per cent. in efficiency. A further run of 96 hours at 3 volts produced no change in any lamp. It must here be stated that the amount of light emitted for a given wattage was, however, generally speaking, about 18 per cent. better from the British lamps. Three of the lamps were then taken and each placed in turn in the lampholder and it was carefully noted what volts had to be across the filaments for a similar reading of the photometer. The last lamp tested was left in the lamphouse as the first standard light source, while the other two bulbs were carefully put away till such time as might be thought necessary to compare the used lamp against a new calibrated one and if necessary replace the old one.

Earlier it was mentioned that the frame which holds the diffusing screen is rotatable. This is done for the purpose of replacing the diffusing glass with perhaps, say, a piece of sheet metal, paper or cloth and then after rotating the frame by a given angle measuring the amount of light reflected, the photo-cell of a photometer being placed so that the reflected light falls on it. By such methods one can arrive at the different reflective values of any required material.

It is of course understood that when comparing photo-cells it is necessary to put them all the same distance behind the diffusing screen, the recommended distance being from six to twelve inches.

Another way in which the light source may be used is to remove the diffusing screen from the frame and project the actual image of one round

aperture on to the cathode of a photo-cell; by moving the cell so that the light falls on different areas of the cathode one can find out if one spot is more sensitive than another.

It is now only left to find the approximate value of our light source in lumens. It has been previously pointed out that one candle power is equal to  $4\pi$  lumens. Supposing one takes a 40 c.p.  $\frac{1}{2}$ -watt lamp which if run at the correct rated voltage will give approximately 80 c.p. (the bulb should be clear). Next project, say, nine apertures of light on to the diffusing screen, measure the diameter of these light spots and calculate the total area of the nine spots; now move the 80 c.p. light source nearer or further from the diffusing screen till the projected spots of light just vanish or appear. Note the distance from the lamp to the screen, and calculate the area of a sphere which has a radius equal to this distance. Over the area of the sphere will be distributed  $4\pi \times 80$  lumens and as the area of the light spots is known, the value of light source, in lumens, is approximately arrived at.

### NEXT MONTH.

The first of a comprehensive series of articles on television experiment and the equipment of a television laboratory.



# THE AMPLIFIER FOR THE AMATEUR TRANSMITTER

Here are details of the amplifier suitable for use in conjunction with the Amateur Experimental Transmitter which was described last month. Experimental transmitting is a development which many

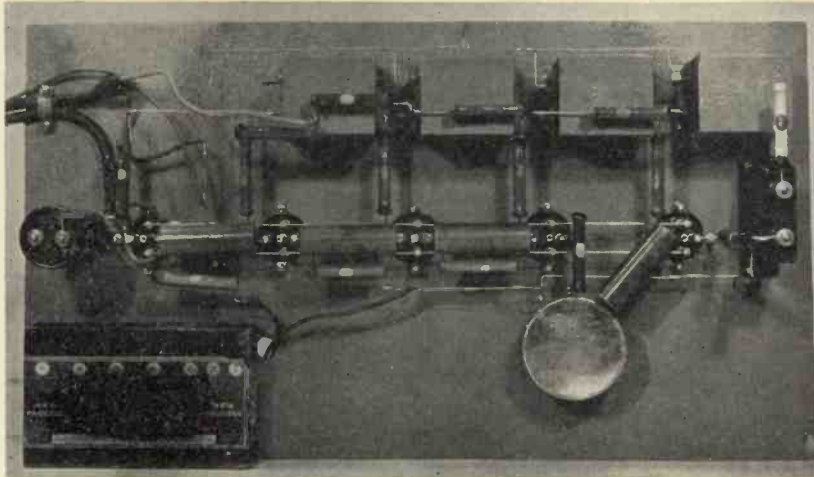

The entire amplifier is mounted on a flat piece of wood, and this photograph shows the underside.

enthusiasts are taking up and investigating the various problems which arise. Even though the transmissions are confined to line work, it will be found that the subject is full of interest.

IN the article in last month's issue, the main constructional features of the transmitter were described. The particulars given were sufficient to enable the optical system to be practically completed, and this month it is intended to give details of a suitable amplifier for use with this equipment. A short article giving final constructional details and operating hints will be given next month.

In view of the growing interest in cathode-ray reception, it was thought that many would appreciate an amplifier capable of modulating a cathode-ray tube direct, and the amplifier described fulfils this condition. An absolute minimum of distortion in the amplifier associated with a television transmitter is essential, and it is generally desirable to utilise a multi-stage amplifier having a low gain per stage rather than a smaller number of stages having a correspondingly greater stage gain. In this amplifier, shown diagrammatically in Fig. 1, the overall magnification of the five stages is some 15,000 times.

## The Layout

The layout of components is indicated in Fig. 2, and while the measurements can be modified to suit other components than those specified, it is not desirable to depart from the original layout or difficulty may be experienced from instability. A chassis of 3-ply has been adopted in preference to metal, in order to reduce the stray capacities, and it is easily

adaptable to chassis construction. If the reader prefers to use baseboard mounting components, a  $\frac{1}{2}$  in. wooden baseboard can be used having similar dimensions to those given for the chassis used in the original amplifier.

If 3-ply is used the amplifier can be completely assembled and wired before fixing the sides, thus simplifying the wiring. The holes for mounting the chassis-type valve holders, have been placed on the assumption that the coupling condensers used are some 2 in. in length, and should the reader wish to employ condensers differing from this length, the distance between the valve holders will have to be modified accordingly.

Having decided on the spacing of the valve holders, holes can be drilled in the chassis through which the legs of the holders can be passed. A suitable size of hole for Clix valve holders is  $1\frac{1}{4}$  in. This size enables the pins to be well away from the sides of the hole, and yet leaves ample room for the fixing screws.

As will be seen from the photograph, the amplifier is arranged so that the coupling condensers form their own connecting wires between the anode and grid of each succeeding valve, and the grid and anode resistances are soldered to the condenser leads. The sketch (Fig. 3) shows how the anode and grid resistances can be soldered to the appropriate coupling condensers so that the am-

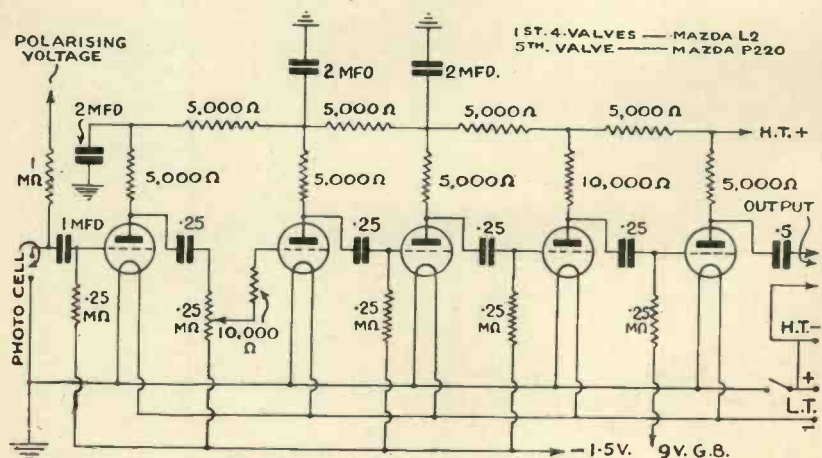
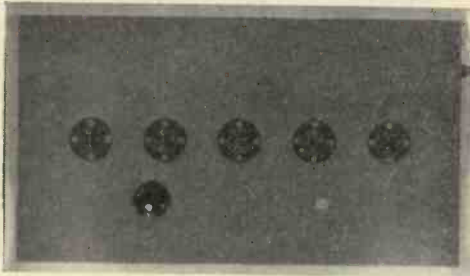

Fig. 1.—The circuit diagram of the transmitter amplifier.

plifier is virtually wired up in units and each unit dropped into place after the filament bus-bars have been soldered to the valve holder legs.



Only the valve holders are mounted on the upper side of the baseboard, as this photograph shows.

With an amplifier of this description, considerable care has to be taken with decoupling in order to assure

### COMPONENTS REQUIRED

#### CHASSIS

1 piece 3-ply 18 in. X 10 in. 5 ft. of  $\frac{1}{4}$  in. white wood (width dependent on depth of chassis).

#### RESISTANCES

15—1-watt Erie resistors; 8—5,000 ohms; 2—10,000 ohms; 1—5 megohm; 1—1 megohm; 3—.25 megohm.

#### POTENTIOMETER

(Centralab); 1— $\frac{1}{4}$  megohm.

#### CONDENSERS

4—.25 mfd. (T.C.C. Tubular); 1—1 mfd. T.C.C. Manbridge Condenser; 4—2 mfd. T.C.C. Manbridge condensers; 1—.5 mfd. Dubilier condenser, type 9200.

#### VALVE-HOLDER

5—chassis mounting 5-pin (Clix).

stable working from a high-tension battery common to all stages, and reference to Fig. 1 will make the arrangement clear. The supply of one stage from the decoupling of the

succeeding stage produces neutralisation of such feed-back as is present owing to the voltage components in the H.T. line to succeeding stages being 180° out of phase.

A volume control is included in the grid circuit of the second valve, together with a grid-stopping resistance, but if these can be dispensed with in individual cases, an improvement in the quality of the images obtained will be noticed. As the maximum sensitivity was desired in the original model, a 5-megohm grid circuit impedance was used for the first valve, though if the amplifier is used near to any A.C. mains-operated equipment, considerable trouble will be experienced from hum. If screening the amplifier and leads to the photo-cell does not reduce the hum sufficiently, the only course to take is to reduce this resistance to as low a value as 1 megohm. Whilst this alteration leads to a lower overall sensitivity, the picture quality will be slightly improved, and where a cathode-ray tube is being used for reception, the slightly smaller signal is still adequate to produce full modulation.

As the decoupling condensers used in the amplifier illustrated were manufacturers' models which cannot be obtained through the retail trade, it has been thought advisable to give no actual drilling centres for condensers and to leave this part of the layout to the reader. A suitable centre line on which to mount standard

Manbridge condensers is shown, and a slight reduction in the size of chassis employed may be possible.

No terminals for input and output have been included in the design, and as the condensers through which these points are brought out have terminals, no useful purpose would be served though, provided care is exercised, no trouble will be experienced from instability if short un-screened leads are taken to terminals mounted on the chassis. The battery supplies are taken by flexible leads direct to the components in the amplifier, and it is recommended that the grid bias battery be mounted on the chassis so that the leads to it can be made as short as possible.

### Bias

In an attempt to render the amplifier more self-contained, a considerable amount of time was spent in experimental work on automatic bias,

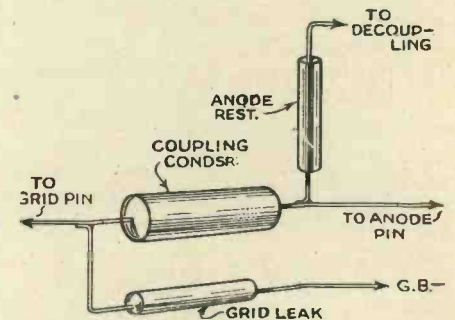

Fig. 3.—Sketch showing how the anode and grid resistances are connected to the coupling condensers.

but no economical system was found which gave absolute satisfaction on the score of bass loss, and unless one is prepared to spend unlimited sums of money on high capacity condensers, a bias battery is by far the best proposition, requiring as it does so little attention.

It is possible, however, to polarise the photo-cells from the same battery as supplies high-tension to the rest of the equipment, though a separate supply is naturally to be preferred.

The sides of the chassis used by the writer measured some 3 in. high, and while this dimension is adequate to accommodate most makes of components, it is advisable to check up the height of the decoupling condensers used before obtaining the materials in order to avoid unnecessary trouble and expense. In the dimensioned diagram, Fig. 2, all holes having no dimension marked, should be drilled to clear 6 BA screws.

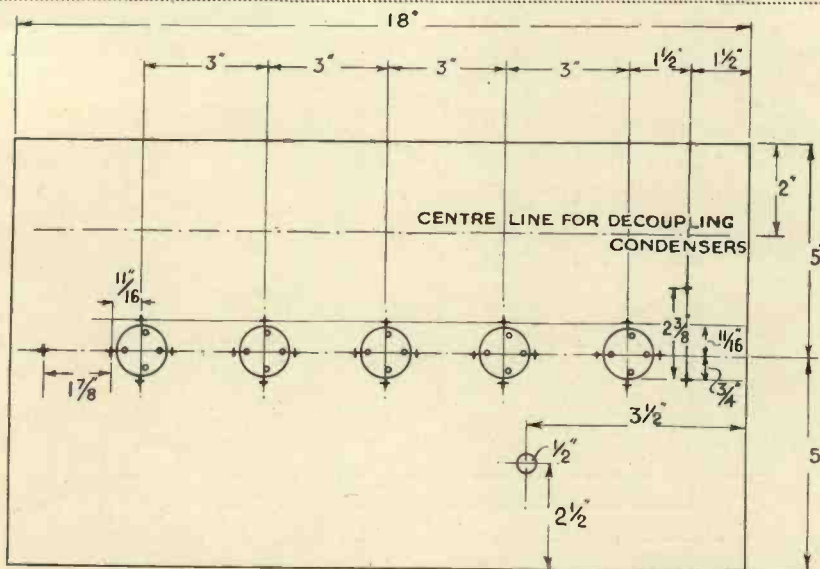

Fig. 2.—A dimensioned drawing of the layout of the baseboard.



# HOW YOU CAN EXPERIMENT WITH PHOTO-ELECTRIC CELLS

*A simple explanation of the construction and operation of the photo-electric cell was given last month. In the article below Dr. C. G. Lemon explains the practical applications of the cell and how experimental work can be conducted.*

ONE can quite easily build up a burglar alarm or door alarm using the circuit given by Fig. 6 (Fig. 1 below), of the August issue, although for the former it would be advisable to use an invisible beam of light, either ultra-violet or infra-red; these invisible beams can quite easily be obtained by means of suitable light filters.

Now, if we project a beam of this description across the property which it is desired to protect, and the photo-cell on the opposite side, any interruption of the light ray will immediately cause the anode current of the amplifying valve to rise. If a relay of the Post Office type is in series with the anode lead, it will now be brought into operation and so operate an external system of alarms or indicators.

In talking films it is the intensity of the light, varying at a frequency controlled by the strip at the edge of the film, that gives rise to the speech currents, etc. This is suitably amplified and passed on to the loud-speaker.

A gas-filled cell is generally used in this position, although the output, at a given light intensity, is not proportional to the impressed frequency, but varies, as shown in Fig. 2, curve (a). The vacuum cell, however, does not suffer from the defect (curve (b)), but needs further amplification.

This variation of photo-emission with impressed frequencies ranging from 50 to 10,000 cycles per second is not due to time lag in the cell itself, but it is probably caused by the positive ions generating secondary electrons on impact with the cathode, these secondary electrons again colliding with gas molecules and producing more positive ions, and so on, until a steady state is reached.

## Uses for Photo-cells

A few of the other uses of the photo-electric cell are: television; transmission of still pictures; auto-

matic street lighting; colour matching; colour temperature measurement; comparison of the densities of opaque substances (paper, cloth); selection of materials with regard to their colour (selection of cigars);



*A photo-cell intended for television and other purposes where only small illumination is available. This is the X41 made by the Oxford Instrument Co., and at one metre from a 40 watt lamp the vacuum type gives an output of 10 micro-amps.*

measuring the candle power of lamps; detection of smoke or dust in the atmosphere (smoking chimneys); stellar photometry; automatic counter, and many other chemical and physical measurements, such as: automatic titration, observation of

cell are known, and it will be of interest to describe some work that has been carried out on the photo-electric method of colour matching.

## Colour Matching

In previous types of colour matching apparatus it has always been found necessary to incorporate two photo-electric cells with dissimilar colour frequency characteristics.

This method of colour determination is satisfactory from certain points of view, such as extremely slight changes of colour, but suffers from the fact that it is more costly to secure two cells with widely differing characteristics and also with somewhat similar outputs. The similar outputs are necessary in order to obtain equilibrium for widely differing colours, and that colour changes towards one or the other ends of the spectrum is indicated by the microammeter or indicator moving to one or the other sides of the zero line.

Bearing these facts in mind, and also with a view to the construction of an efficient and easily operated

*Fig. 1.—An amplifier circuit suitable for use with a photo-cell. This circuit can be used with such devices as burglar alarms, etc.*

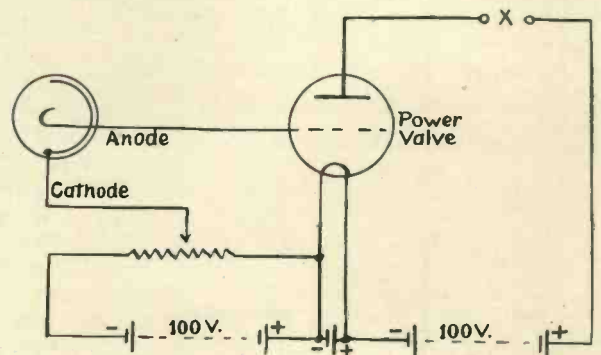

the growth of suspended particles in solution; measurements of spectroscopic plates; testing colour of dyeing solutions against standards.

Quite a number of other applications will suggest themselves when once the possibilities of the photo-

colour comparing device, experiments were conducted with two sodium vacuum type photo-electric cells with identical colour frequency characteristics, and incorporating colour filters.

The first experiment which had to

EXPERIMENTING WITH PHOTO-CELLS

be made was the selection of two suitable colour filters, which when one of each was applied to the photo-cells, gave then a definite and opposite colour frequency characteristic. Using the above-mentioned type of

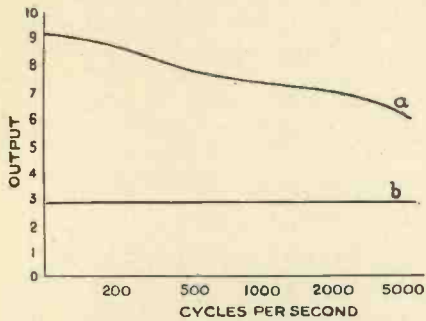

Fig. 2.—Curves showing the characteristics of gas-filled and vacuum cells.

photo-cell and suitably dyed gelatine colour filters, the response curves were found to be in opposition, as can be seen from curves 1 and 2, Fig. 3.

It can be seen, therefore, that the difficulty of using and obtaining two photo-cells of different colour sensitivities is overcome.

With the selection of the suitable colour filters, the next step was constructing an instrument which could be used for transparencies, or opaque substances; in the first case liquids, coloured glass, celluloid, paper, etc., and in the second case, thick cloth, wood, metals, or any dense materials.

The circuit which was used for amplifying the output of the two cells is shown by Fig. 4. This is a bal-

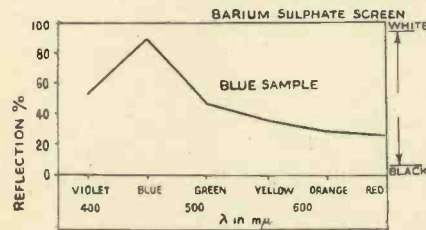

Fig. 5.—Curve showing graphical representation of a colour with the standard a screen of barium sulphate.

anced circuit; the anode current from each valve passes in opposite directions through the indicating meter and so a zero deflection is ob-

tained. Now, if the two cells are equally illuminated, the zero deflection will still be maintained, as the anode current of both the valves will be equally reduced, but if one of the cells receives more illumination than the other, the amplifier will be instantly thrown out of balance, and an indication will be observed on the meter, whose value will depend on the difference of illumination falling on the two cells.

Now in front of one of the cells a blue colour filter is placed, and a red filter in front of the other. Turning again to Fig. 3, we see that the spectral sensitivity of the two cells are as curves 1 and 2. If we now allow the reflected light from a piece of green cloth to fall equally on the two cells, the output from one cell will be twice as great as the other and so a certain deflection will be obtained on the indicating meter. By interposing a shutter in front of the cell which is giving the greatest

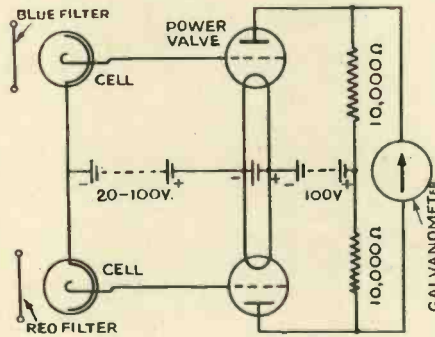

Fig. 4.—Circuit showing use of two cells for colour matching.

output, the current can be cut down in this cell until the amplifier is again balanced.

If the sample piece of material is now changed for another piece which has a slightly differing colour, it will instantly unbalance the apparatus; colour changes which are so slight as to be imperceptible are easily observed by this apparatus. Further tests were carried out with various kinds of substances and in each case an indication of any colour divergence was immediately shown.

To give an instance of the sensitivity of this particular apparatus, a test was carried out on an incandescent electric lamp, which had a

series resistance of approximately 0.01 ohm in one of the leads, which could be shorted out by means of a switch. Using a spot-light galvanometer as the indicating instrument, and shorting out the resistance, a

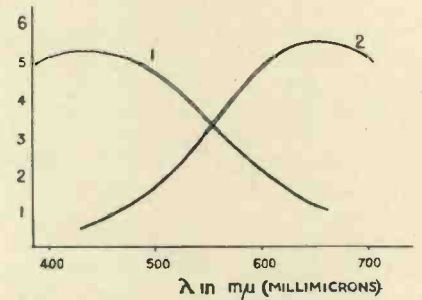

Fig. 3.—Curves showing the selection of cells with opposite colour frequency characteristics.

very large deflection was obtained; actually, the variation of the temperature change amounted to approximately 0.2° Centigrade. It can be seen, therefore, that this form of colour temperature measurement is a great deal more sensitive than visual methods.

A different type of colour matching apparatus can be constructed—the essential difference between this type and the one previously described is that besides indicating whether two materials are identical in colour, it will give the colour content of the material.

When one is looking at a coloured object, such as a flower, a piece of cloth, etc., the light which falls on the retina is never a simple mono-

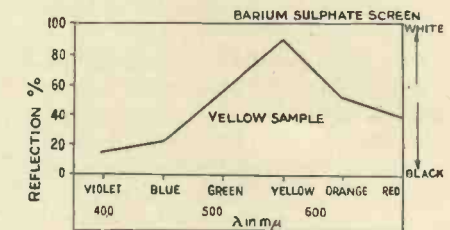

Fig. 6.—A typical graph of a colour comparison.

chromatic radiation such as is observed in spectrum analysis, but is a compound mixture of a large number of individual radiations, each



## POSSIBILITIES OF THE PHOTO-CELL

having a definite wavelength and intensity.

The intensity of an individual radiation may be defined as the position it occupies in a scale whose boundaries are black and white, while its frequency, colour, or wavelength, can be indicated by its position in the spectrum.

Bearing these facts in mind, it would appear that the most simple method of defining a colour would be by means of graphs whose abscissæ are calibrated in wavelengths of the component radiations, and whose ordinates indicate the relative reflection of a particular sample at any predetermined wavelength, as a percentage of white; because a colour is primarily white, with a subtraction of a more or less number of complimentary wavelengths.

Therefore, a graphical representation of a colour is indicated in Fig. 5, where a yellow is taken as the dominant and the standard as a screen of barium sulphate, which is usually used as a white standard.

### Colour Intensity

The intensity of a colour or its purity depends on the position it occupies on the scale between white and black; the higher the dominant and the lower the complementaries, the more intense is its colour, and in order to give an approximate indication as to the apparent intensity of a sample's dominant colour, it is necessary to subtract from the dominant figure the complimentary reading.

The figure of purity can never be more than approximate as there is no absolute white standard, nor is there any pure mono-chromatic filter, that is, a coloured filter which will only pass light of one wavelength; but as this description refers to an apparatus for giving an approximate colour-reflection intensity—characteristic of any sample that may at any time be reproducible—it fulfils its purpose in indicating whether one sample is comparable to another or of defining the colour of a sample as observed by the apparatus.

The elimination of the eye in estimations of this kind has led to a greatly increased accuracy in arbitrary measurements. The electrical

eye, which replaces the human organ, is a caesium photo-electric cell, the constancy of which has to be irreplaceable.

The colour frequency characteristic of this cell is similar to that of the human eye, which makes its measurement of samples, etc., more nearly that of the human organ.

If we connect up the cell as in Fig. 1 and allow a beam of white light, which has been reflected by the standard barium sulphate screen to fall on the cathode of the photo-cell, the current passed will be indicated on a milliammeter connected at X, and the value of this current is dependent on two things:—

- (1) Its colour.
- (2) The reflection property of the material.

Now if the standard is illuminated with a comparatively monochromatic beam of violet light (which is obtained by passing the beam through a light filter) a certain value of current will be passed by the photo-cell, the amount of which depends on the percentage of violet reflected by the standard; this reading is noted and a blue filter is interposed. The readings are then noted for the whole series of monochromats: violet, blue, green, yellow, orange and red.

The standard BaSO<sub>4</sub> screen is then removed and the sample to be tested placed in position. The filters are then interposed and readings again taken.

### Making Comparisons

If the readings are plotted, the graph may appear as in Fig. 6 which shows that the sample was blue as compared with the standard, also, that it has a degree of "purity" which may be expressed as 42 per cent. and whose surface has a total reflection of 45.5 per cent. (this figure is obtained by taking the average of the six readings).

The graph of this particular sample, although expressed empirically, is relatively accurate when comparing a number of other samples. The results are always repeatable, graphs can be taken of various coloured materials which can always be filed for future reference and used as check against supplies.

### Conclusion

You may wonder what the future may hold in store for the photo-cell and it will be recalled that the earliest photo-electric effect was scarcely detectable by a gold leaf electroscope. Highly polished surfaces of zinc or aluminium quickly tarnished under the bombardment of ultra-violet radiation, and the photo-electric current decreased quite rapidly to an extremely small fraction of its initial value. As soon as Elster and Geitel found that an amalgamated zinc surface retained its emissive properties with reasonable constancy for several hours, they were ready to suggest the use of this photo-electric effect for ultra-violet photometry.

With the development of the science of photo-electricity, the improvements in the photo-electric surfaces had led to a number of definite applications, and this of course, gave new impetus to the construction of better cells which would accomplish results not obtainable at the time, such as the photometry of the visible radiations. This resulted in the discovery of the sensitivity of the alkali metals to ordinary light, and with the production of these types of cells, new applications were discovered and now it seems that the oxide cells will soon hold the field. At the present time the practical values of current that is passed by the photo-cell, and the satisfactory stability and longevity that is given by the modern cell, have gained the confidence of designing engineers and in general a wider scope of public interest.

Messrs. The Bennett Television Co., of Station Road, Redhill, Surrey, inform us that a new edition of the Constructor's Handbook is in course of preparation and that it is proposed to give purchasers the opportunity of securing free television apparatus to the value of £1 1s. 0d. in return for a postcard giving a description of their own preferred television receiver which can be made at a cost of £5 or less. The award will be made to the writer who sends in the best details of the most popular model. Full particulars may be obtained from the Bennett Co. upon mention of this Journal.

# APPARATUS FOR THE EXPERIMENTER

## The Telelux Neon Lamp

Appreciating the limitations imposed by the use of an ordinary neon lamp, British Television Supplies, Ltd., of Bush House, London, W.C.2, have modified the beehive pattern lamp in such a way that glare

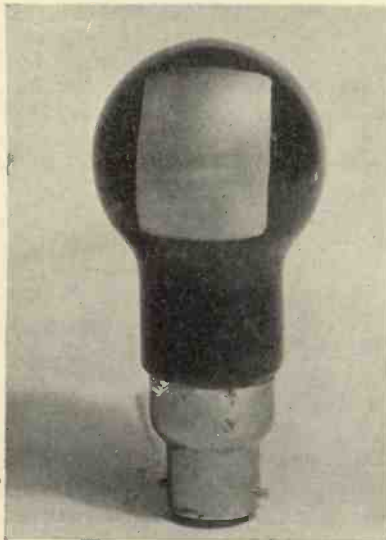

*The Telelux specially-treated neon lamp.*

and uneven lighting is eliminated. With the exception of an aperture, the whole of the surface of the lamp is provided with an internal reflecting surface so that the greatest quantity of light is emitted. This reflecting surface is further treated on the outside so that it quite opaque and in addition the aperture is frosted so that the light is diffused evenly over the whole scanning area. The results obtained from this lamp showed a marked improvement over those obtainable from the ordinary type and we have every confidence in recommending it to readers.

## Cathode-ray Units

Working in conjunction with Messrs. Edison Swan Electric Co., Sound Sales, Ltd., have developed a number of special high-voltage power transformers for use with cathode-ray tubes, and are now listing a complete exciter unit which measures only 8 in. by 6 in. by 7½ in. Housed in a black crystalline case the unit incorporates provision for modulation of the tube by means of linking terminals, and a further refinement con-

sists of an optional method of heating the tube cathode, either by a 2-volt battery or raw A.C., provided by the excitor unit for general work, wave form measurements, etc. Raw A.C. can be used for feeding the tube, but in some special cases battery feed may be preferred. In the latter case, it is only necessary to re-

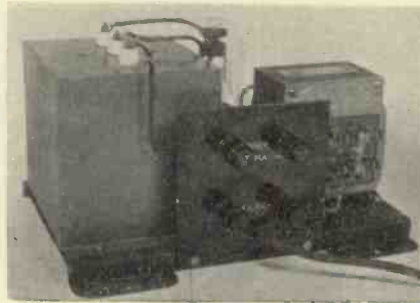

*Sound Sales cathode-ray exciter unit.*

move two links (provided in an accessible position) and connect the battery to L.T.+ and L.T.- terminals.

In addition to the cathode-ray excitor unit, a special 1,500 volt time

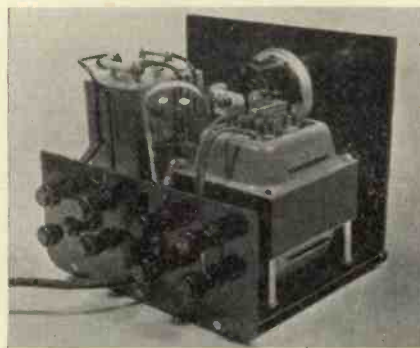

*Another cathode-ray unit made by Sound Sales—a double time base.*

base eliminator is available. This unit is housed in a substantial crystalline finished case, and equipped with a universal transformer which provides 1,500 volts smoothed D.C. Rectification is carried out by an Ediswan M.U.1 valve. Adequate smoothing is provided by a section-wound 100-henry choke, and two very substantial 1,500 v. working 4 m.f., paper condensers, having an output of 1,500 v. at 10 mA, with a further output of 4 volts at 4 amps. raw A.C., this unit provides an ideal means of driving the two-valve time-base unit employing M.R.A.C.1 mer-

cury-vapour relays. The price is £7 10s.

A double time-base for use with either 30 or 120-line transmissions, is also made together with a special 4-watt Paraphase push-pull amplifier, which can be instantly converted to give 12 watts undistorted output by the substitution of PP5/400 valves in place of PX4. Independent variable grid bias to each valve, optional H.T. voltages, etc., provide a ready means of instantly carrying out this conversion; specially built amplifiers are available at £19 10s., complete with valves. Full particulars may be had from Sound Sales, Ltd., Tremlett Grove Works, Junction Road, Highgate, N.19, upon mention of this journal.

## A Viewing Lens

H. E. Sanders & Co., of 4 Gray's Inn Road, W.C.2, have submitted for test a 4-in. viewing lens which has been specially manufactured for use with visors of the disc type. Spe-



*The Sanders lens for disc visors.*

cial features of this lens are that the glass is almost white and that by careful attention to the grinding of the surfaces—the lens is bi-convex by the way—great magnification is obtained without any observable distortion. This means that almost the entire area of the lens can be used and the result is a considerably enlarged picture. At the price of 4s. 6d. this article is excellent value.





## HOW SCANNING DEVICES COMPARE

**I**T was explained last month in this section that some system of scanning both in transmission and reception of television is essential according to our present knowledge; in other words, the picture or image must be divided into a number of separate units at the transmitting end, the light values of these units be converted into corresponding electrical values which are then transmitted, and then at the receiving end these electrical values must be reconverted into corresponding values of light units which are thrown upon the screen or viewed directly in their correct position and sequence.

The actual scanning is a fairly simple matter, and it can be accomplished in a number of ways, as, for instance, by means of oscillating mirrors, the simple scanning disc, the mirror drum, the endless film, the mirror screw and several variations of these devices. There is, however,

so that the novice may know where he stands in making a choice.

Unfortunately there is a very broad division between devices which permit of screen projection and those

small size, it is usual to employ a lens through which the image is viewed, and the picture has then an approximate height of  $3\frac{1}{2}$  inches.

There is, of course, a certain amount of disadvantage in thus magnifying an image, for some amount of distortion is bound to result, though this does not become apparent unless the magnification is pushed too far. There is one more disadvantage in the use of apparatus of this kind, and this is that as the light source is a neon lamp, the colour of the picture is the peculiar pink which is associated with this type of illumination.

Naturally such simple apparatus is not without its advantages, and probably the greatest of these is the comparatively small input which is

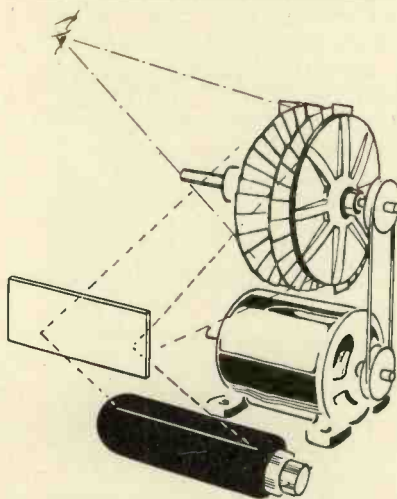
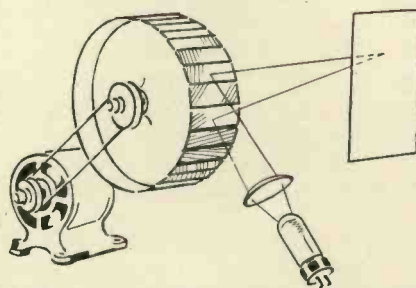
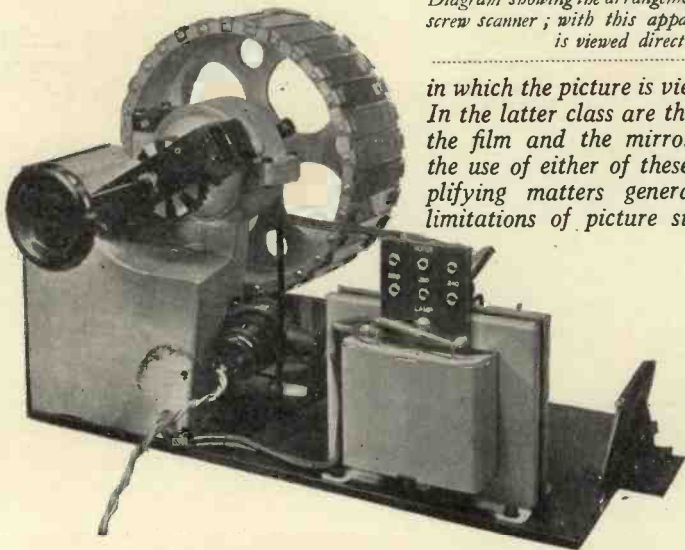

Diagram showing the arrangement of the mirror-screw scanner; with this apparatus the image is viewed direct.

in which the picture is viewed directly. In the latter class are the simple disc, the film and the mirror screw, and the use of either of these, whilst simplifying matters generally, imposes limitations of picture size and bril-



The scheme of a mirror drum projector using a directly modulated source of light.



A very fine example of the mirror drum scanner; the complete chassis of the Baird drum projector

considerable variation in the efficiency of these different types of scanners into which many factors enter, and it will be useful to review these briefly

liancy. The simplest of all is the disc, and the actual picture produced by this is approximately  $1\frac{1}{2}$  inches high by  $\frac{3}{4}$  inch wide. Because of its

required to produce a picture; in fact, at reasonable distances from the transmitter quite good pictures can be received with the average three-valve wireless set. Another important advantage is the simplicity of one type of apparatus, which merely consists of a sheet metal disc with a number of holes in it which is caused to revolve at a speed of 750 revolutions per minute. Could anything be more simple?

Simple though the disc receiver is, properly constructed and operated it produces remarkable results, and there



are commercial machines on the market which only require connection to the lighting mains and are as easy to operate as the average wireless receiver.

The next class of apparatus is the mirror drum, and this possesses the very decided advantage that under certain conditions it is possible to utilise the full value of the light with the exception of the small losses due to absorption in the reflecting surfaces and lenses.

In the case of the mirror drum it is possible to utilise either directly modulated light, as, for instance, that produced by a special type of neon lamp which gives a point source, or a constant source of light which is modulated at some point in its passage to the screen. Lamps that can be directly modulated have certain

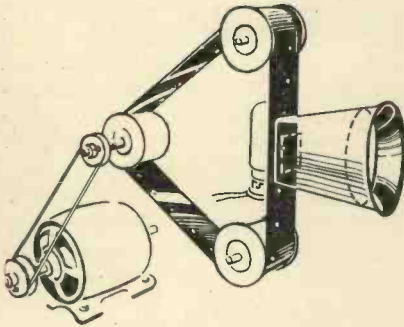

A scanning device using a film.

limitations in the amount of light which they are capable of producing, and this, of course, imposes a limit upon the size of the picture that can be projected. However, lamps of the crater-point neon type or the mercury-vapour recording lamp will provide sufficient directly modulated light to illuminate a screen measuring 7 inches by 3 inches.

It might be thought that the obvious solution of this difficulty of providing a sufficient value of light would lie in using a lamp of the ordinary incandescent projection type and modulating the light produced afterwards. However, there is another snag here, and this that the light valve which must be used to modulate the light only passes about 15 per cent. of the total. This means that if we use a lamp of 200 candle-power something rather less than 30 candle-power is available for producing the picture.

Increasing the original light intensity presents further difficulties in that

very much more power is necessary, which would necessitate the use of wireless apparatus ordinarily beyond the reach of the amateur. Modulation of light of a value of 200 candle

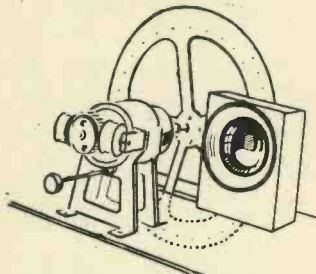

The simple disc receiver.

power is about the limit which can conveniently be accomplished by the amateur.

From the foregoing it will be clear that the efficiency of a receiver is bound up in the matter of our ability to modulate a sufficient value of light and use this in the best manner. Although each system has certain inherent disadvantages, these are not such as to preclude their use in receivers, which, all things considered, give excellent results in amateur hands. Operating conditions in either case do

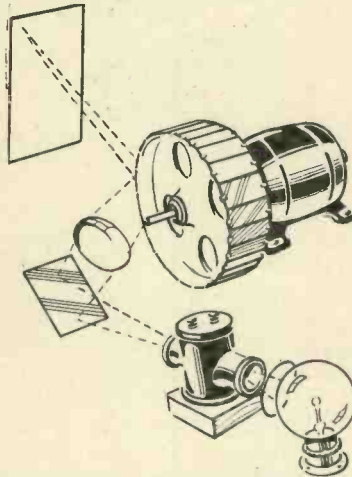

The arrangement of a mirror drum projector using a constant source of light and a Kerr cell for modulation.

not present any difficulties, though naturally they are rather more simple in the case of the disc machine, and all come within the abilities of anyone who has an elementary knowledge of wireless.

Picture size has a very important bearing on the cost and upkeep of a television receiver and, as remarked

before, there is no intermediate stage between the very simple apparatus and that capable of projecting the picture on a screen or providing a picture of dimensions exceeding a matter of a couple of inches in height. The principal reason for this is obvious—much greater illumination is necessary, and this means a greater value of modulated light, the provision of which is one of the major problems in television reception.

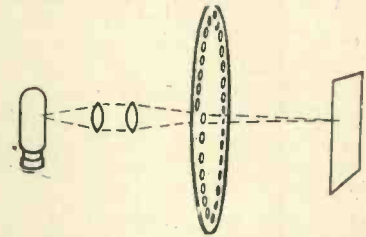

Projection with a lensed disc machine.

Direct modulation of the light source is in many respects more easy than the modulation of a constant source of light, so in seeking a method of increasing the picture size and still keeping the apparatus as simple as possible we have to consider what means are available of using a lamp of the neon type for this purpose. One device which lends itself to this purpose admirably is the mirror screw. This consists of a number of flat metal plates with one edge silvered and arranged in a formation somewhat similar to a spiral staircase.

With the mirror screw the image is viewed directly, so it is obvious that the size of the picture will depend upon the size of the screw assembly. Assuming the mirrors to be three-and-a-half inches long and one-twentieth of an inch thick, then the resulting size in the case of a thirty-line screw would be  $3\frac{1}{2}$  by  $1\frac{1}{2}$ . A line of light is used with this type of apparatus, and it will be evident that at any given instant, as only one mirror is reflecting a thirtieth part of this line, the total light efficiency is rather low. In addition some loss of light is occasioned by the fact that all the light is not concentrated in the line. The mirror screw, then, is not any more efficient than the disc machine, but it has the advantage that the apparatus can be kept within reasonable limits as regards size, and yet be made to give a larger picture than is obtainable with a disc machine unless the latter be of unduly large dimensions.



# STATIC NEED NOT SPOIL YOUR PICTURES

*A few crashes or an intermittent background mush can be tolerated with a radio receiver, but it is a different matter altogether with television, for interference can easily spoil the picture. This article, by Kenneth Jowers, describes the various expedients which may be used to prevent trouble of this nature.*

WITH the increasing use of electrical apparatus, man-made static is steadily growing worse, particularly on short waves. Without legislation to stop it the only thing to do is to get down

go further and buy special components.

You must remember that in many cases the pick-up is not primarily due to the aerial, but to the lead-in wire coming close to other noisy conduc-

interference aerial: firstly the doublet system with transposed lead-in wires (Fig. 1), which does not use any direct earth connection. Secondly, a standard aerial with screened down-lead and counterpoise earth

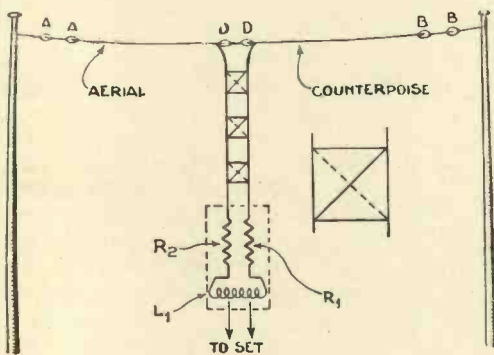
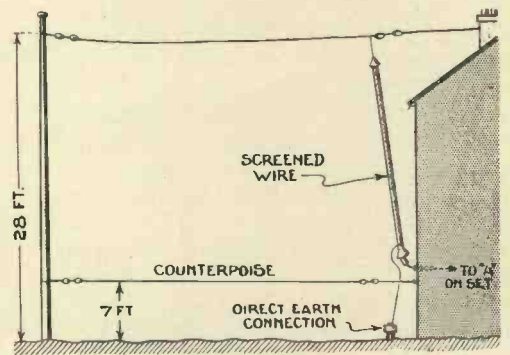

Fig. 1 (left).—The most efficient aerial possible to erect. The doublet system.

Fig. 2 (right).—How to use a screened downlead with a standard aerial and a counterpoise

Fig. 3 (below).—This type of aerial is commonly called a doublet with spreaders, and is intended for short-wave reception. If this aerial is used, circuits 5 or 6 must also be employed.



to business and try to stop it yourself. Generation of "mush" and the use of apparatus that interferes with radio reception is an offence in many countries, but a different state of affairs exists in this country where all and sundry can use hair dryers, violet-ray apparatus, small motors and other domestic gear with a total disregard for the trouble caused.

During the past few months a considerable amount of research work has been undertaken with noise reducing aerials, screened down leads and impedance balancing couplers. Much progress has been made so that now interference generated locally can be cut out or in extreme cases reduced by 70 to 80 per cent.

It is essential that firstly the source of interference is located. In a factory area this will be difficult but the approximate location is all you want. The aerial should then be erected as far away from the source of the interference as possible—placed end on to it and not broadside as this will also help to reduce the pick-up. In some instances merely by altering the direction of the aerial in this way the pick-up has been so greatly reduced that there has not been any need to

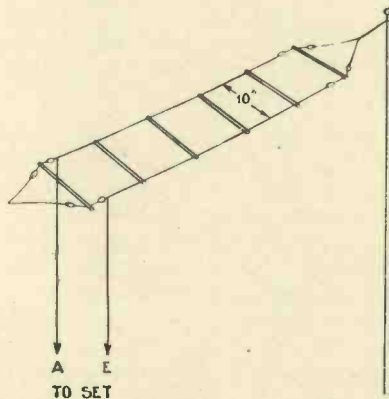

tors, such as phone wires and mains cables. Therefore, even should the aerial be quite free from mush pick-up the trouble will not be overcome unless the lead-in is completely screened.

During my experiments I noticed that a considerable amount of interference was picked up by the earth lead, particularly in flats, where it was taken to a steel window frame or the gas pipe and when a normal aerial system could not be erected.

By the way, when I refer to the aerial I include both the aerial and the earth connections.

I have tested several types of anti-

(Fig. 2), and thirdly a special short-wave aerial (Fig. 3). I have also tried a standard aerial and earth connections with a simple screened downlead (Fig. 4). All of these systems were effective, but in different degrees. There was always a slight decrease in signal strength and to overcome a great proportion of this defect it was essential that some regard be had to the aerial length so as to obtain the maximum pick-up.

Some are not able to erect either the aerials of Figs. 1 and 2, but almost everyone can use a standard aerial with a simple screened downlead. No doubt the most efficient arrangement is the doublet system, but only when it can be erected at a distance from the source of interference. Remember that with this system the length of down-lead is not important.

The second method (Fig. 2) was also satisfactory but there was a slight inclination for mush to be picked up on the counterpoise earth connection. The third method was primarily for short waves and with it the detector circuit must be modified to suit. If erected in a satisfactory manner the mush can be reduced by 80 per cent. Roughly com-

paring the four methods, I consider the first and third decreased the volume by less than 10 per cent., which was almost negligible, and at the same time reduced the mush by as much as 70 per cent.

The systems that used a screened down-lead reduced mush by as much as 75 per cent., but the volume also dropped 20 per cent. A point that will interest short-wave fans is that contrary to expectation the use of a screened down-lead, instead of damping down signals increased the pick-up between wavelengths of 20 and 80 metres, provided the aerial was loosely coupled.

How many readers know that a single wire is better for short-waves than a standard wire? Very few, I am sure, but it has been proved that a single wire is the most efficient. The point that I wish to stress is that multi-stranded wire although more efficient on short-waves cannot be compared with 12 or 14 s.w.g. copper wire on wavelengths below 150 metres. The reason for this is quite simple. High-frequency currents travel on the surface of the wire and while stranded wire offers a greater area the actual effect of stranding increases the resistance to high-frequency currents while the reverse applies to good solid wire.

It is essential when putting up noise reducing aerials (when we know

nal strength nullified by the loss in selectivity. So on wavelengths of above 150 metres it is better to effect a compromise between pick-up and selectivity and use an aerial having a total length of about 50 ft.

To obtain the maximum signal

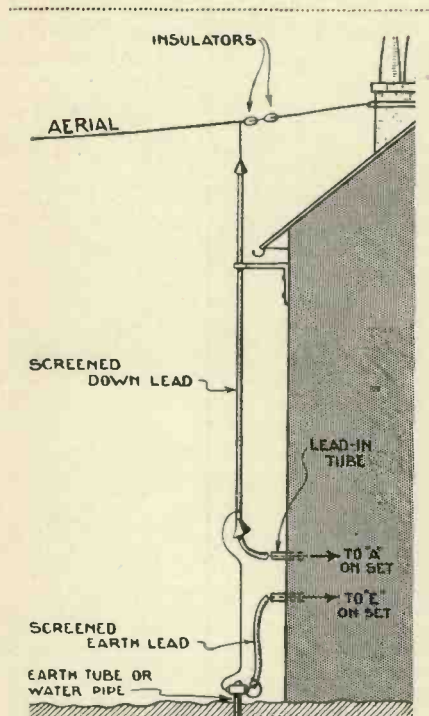

Fig. 4.—A popular method of using a screened downlead with a screened earth connection. The metallised wires must be carefully earthed.

When erecting either the aerial doublet system or the aerial and counterpoise the formula is varied to

$$\text{length of aerial} = \frac{492,000}{f} \times .95,$$

which gives the length of aerial and counterpoise connections, the total length of wire being divided between the two.

Fig. 1 shows how the American type of aerial should be erected. It consists of two lengths of wire between A and D and D and B (which can be determined by the second formula) and a special transposed lead-in wire consisting of two balanced leads which cross over on insulators. These leads are then taken to two resistances R<sub>1</sub> and R<sub>2</sub> and then on to an impedance matching coupler L<sub>1</sub>. The insulator should be grooved diagonally and made of porcelain, steatite or high-quality bakelite, and should be approximately 2 ft. apart.

The average values for R<sub>1</sub> and R<sub>2</sub> are between 150 and 200 ohms on the short waves and between 300 and 400 ohms on the medium waves. The inductance L<sub>2</sub> can now be obtained from Messrs. Ward & Goldstone, who specialise in this apparatus.

The special coupler L<sub>1</sub> has the effect of cancelling out the high inductance and capacity of the long lead-in wires, which means that an aerial doublet, with a 50 or 60 yard

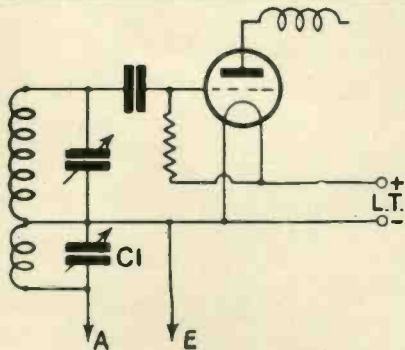

Fig. 5.—This is the way to alter the detector circuit if you use the aerial shown in Fig. 3.

there will be a slight decrease in strength) to counterbalance this as far as possible by erecting an aerial that is broadly tuned to the frequencies that we wish to receive. This is obviously more important on the short waves.

It will be realised that this idea is not always practical, because a tuned aerial on medium waves will be so long that the tuning would be extremely flat and the increase in sig-

strength on the short waves the aerial should be approximately one quarter of the wavelength of the station you wish to hear. For instance, 80 metres is approximately 260 ft. An aerial to give maximum signal strength from an 80-metre station should be 65 ft. in length.

A point of interest regarding this 80-metre aerial is that it will be equally suitable on 40 and 20 metres as the harmonics will be dealt with; but, conversely a 20-metre aerial would not give maximum results on 40 or 80 metres. For those who wish to erect their own aerial on these lines the following formula will no doubt be useful. The results obtained will be as accurate as necessary, particularly as a greater degree of accuracy would mean delving into capacity variations of the different types of aerials.

The formula is, length of aerial 
$$= \frac{492,000}{2f} \times .95,$$
 where f is the frequency of the station.

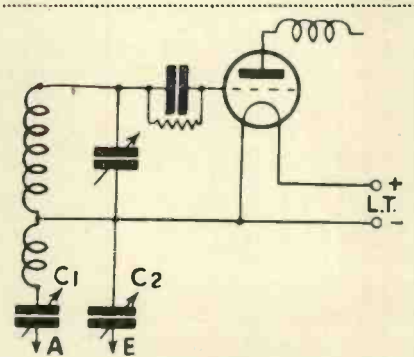

Fig. 6.—An alternative input method to the one shown in Fig. 5.

feeder will function in a similar way to an aerial having a short 10 or 20 ft. lead-in wire. Anode resistances R<sub>1</sub> and R<sub>2</sub> should be shielded and directly earthed.

It must be remembered that an earth connection to the receiver is not necessary; if one is used it is very likely that the whole effect will be spoilt, consequently both lead-in wires must be carefully insulated.

Incidentally it must not be assumed



that a different aerial is required for each station. If it is designed, for example, for 6,000 kilocycles or a 50 metre station, it will cover a very wide band of frequencies.

The system of Fig. 2 is much simpler but very effective. It consists of a standard aerial and counterpoise earth. The main idea is that where the pick-up is obviously due to the earth connection it can probably be eliminated by using a counterpoise earth without decreasing the efficiency of the receiver. While not

tered, as shown in either Fig. 5 or 6. The circuit in Fig. 6 is the more suitable, as it enables you to tune the aerial more accurately to the correct frequency. The coupling coil across the aerial should be adjusted to the fundamental frequency or the second harmonic of the station you wish to receive.

There will be a slight reduction in signal strength but the signal to noise ratio is greatly increased. The only method of using a direct earth lead for short-wave working is shown

far above metal girders or power and telephone lines as possible, bearing in mind that it is easy to effect a compromise between height and unduly long lead-in wire. Usually a mast about 6 ft. above the nearest chimney stack or metal conductor will be found satisfactory.

The lead-in wire, preferably of a special screened type, should have the screening as close to the aerial as possible and be taken straight down to the aerial terminal of the receiver. It is not essential to use a screened

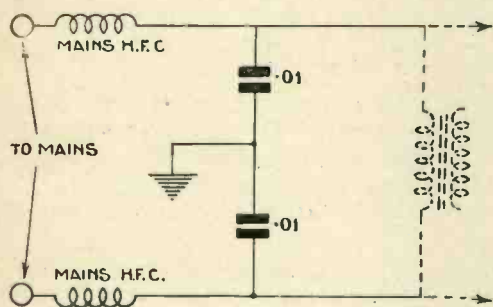
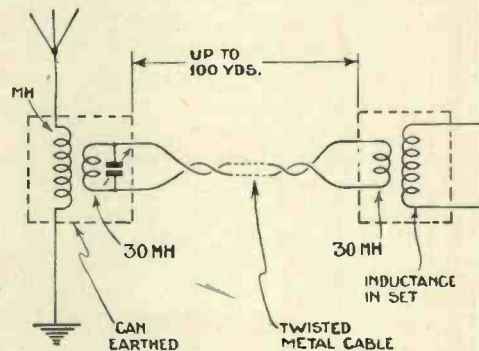

Fig. 7 (left).—A filter for use with A.C. or D.C. mains where pick-up is not solely caused by using an external aerial.

Fig. 8 (right).—A special system of impedance balancing and the effect of long lead-in wires in a circuit such as shown in Fig. 1.



always giving a high degree of efficiency it is certainly very beneficial and the interference not excessive.

When the length of aerial is determined by means of the first formula there will be a decided improvement in pick-up and selectivity. The counterpoise earth connection should be about 25 ft. above the earth level, or if the aerial is erected above the house on a pole it should be about a quarter of the height of the aerial, from the ground.

The short-wave aerial, shown in Fig. 3, is very simple. It consists of what is commonly considered a double aerial with spreaders. These spreaders are made of teak or glass and should be as light as possible. Suitable 10-in. glass spreaders can be obtained from Stratton & Co. Here again the length of either side of the aerial can be obtained from the first formula. The aerial should be erected as high as possible and away from interference, but bear in mind that if the total length of lead-in is too great it will cause damping.

You will see that the conventional flat top and down-lead are not used, as the lead-in wires are taken direct to the receiver and are approximately in the same plane as the two straight aerial wires. It is essential with this aerial that the input circuit be al-

ways giving a high degree of efficiency it is certainly very beneficial and the interference not excessive. When the length of aerial is determined by means of the first formula there will be a decided improvement in pick-up and selectivity. The counterpoise earth connection should be about 25 ft. above the earth level, or if the aerial is erected above the house on a pole it should be about a quarter of the height of the aerial, from the ground. The short-wave aerial, shown in Fig. 3, is very simple. It consists of what is commonly considered a double aerial with spreaders. These spreaders are made of teak or glass and should be as light as possible. Suitable 10-in. glass spreaders can be obtained from Stratton & Co. Here again the length of either side of the aerial can be obtained from the first formula. The aerial should be erected as high as possible and away from interference, but bear in mind that if the total length of lead-in is too great it will cause damping. You will see that the conventional flat top and down-lead are not used, as the lead-in wires are taken direct to the receiver and are approximately in the same plane as the two straight aerial wires. It is essential with this aerial that the input circuit be al-

by Fig. 4. This is a standard aerial using a conventional screened down-lead.

This I find is quite satisfactory and undoubtedly the most popular method. It is comparatively inexpensive and it is easy to erect. It is fundamentally similar to the other wire for the earth connection. It is rather important that the metal covering on the lead-in and earth wires should be effectively taken to "ground" and not to a waterpipe. I must also strongly emphasise that if the screened lead-in wire is not taken high above nearby girders or possible conductors, it is more than likely that the whole arrangement will be ineffective. The loss in signal strength with this arrangement should not be more than 3 decibels on medium waves and 6 decibels on the long waves. I found that on the short waves there was a slight rise rather than fall in signal strength.

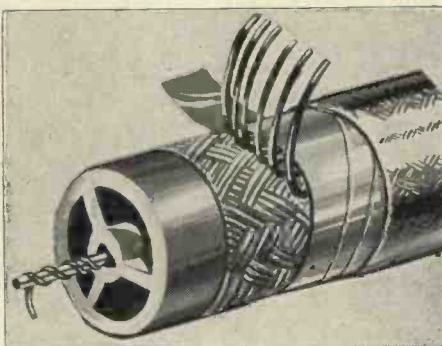

Fig. 9.—This sketch shows the construction of the Ward & Goldstone screened downlead.

The only snag about this arrangement is that owing to limited space the aerial may not be far enough away from the source of interference and instead of the noise being completely eliminated may only be partially reduced. In this case it would be advisable to use the first system with a transposed lead-in wire thoroughly shielded.

Fortunately during the last few months several manufacturers have introduced as a standard line all the equipment likely to be wanted by the amateur who wishes to eliminate annoying interference from a television receiver.

methods, that is, the aerial must be as far away as possible from the source of interference. As the normal lead-in is used without any balancers the aerial cannot be any more than a nominal distance from the receiver, otherwise the effective length of the down-lead will be too great, resulting in flat tuning.

It is advisable to erect the aerial as



# ANSWERS to QUERIES

## Uniform Spacing

In the time base I have built I have trouble in getting uniform spacing between the lines. They tend to close up at one end of the screen. I have also checked the time-base on A.C. waveform and notice the same effect. I also have difficulty in focusing the picture uniformly. Can you suggest the cause of this?—A. A. (Chelmsford).

We have examined your diagram of the double time-base, and can find no reason for irregular operation in the circuit itself. Since the waves are unevenly spaced the time-base is obviously non-linear over its whole travel, and the most probable cause of this is too low a value of H.T. voltage.

You will appreciate that resistance-capacity time-bases, as opposed to diode-capacity time-bases are only linear if the applied H.T. voltage is high enough to ensure that the charging voltage curve does not depart from linearity before the mercury relay strikes. Try raising the voltage to 500, or if this is not possible, an alteration of the values of charging condenser may help.

Without seeing the effect described on your tube it is difficult for us to give a definite opinion, but the cause of poor or patchy focus is most usually too low a cathode temperature. If you have a cathode ammeter, try raising the current by 5 per cent. and see if there is any improvement.

## Receiver for Cathode-ray Tube

(a) Is a 4-valve mains set with a P.X.4. output valve suitable for use with a C.R. tube, and what form of coupling is advisable?

(b) What is the current consumption of the time-base circuit given in the May issue of "Television"?—F.I. (Castle-Bromwich).

In reply to your query, the receiver you describe will be quite suitable for use with a cathode-ray television viewer—in fact the output stage will be unnecessarily large! You will only require about 20 volts swing on the power valve to fully modulate the

tube, and this should be obtained from a series resistance in the anode circuit coupled to the tube by two condensers as shown in the circuit diagram on p. 219 of the May issue of TELEVISION.

Transformer or choke coupling in the receiver is undesirable on account of the risk of phase distortion.

The H.T. supply for the double time-base should be capable of supplying 5-8 mA. A suitable transformer can be obtained from Messrs. Sound Sales, Ltd., of Tremlett Grove, Highgate, and if you are making the exciter circuit for the tube at the same time you can specify two 1,000-volt windings on the same core.

## Projection Lamps for Baird Mirror Drum

I get excellent results with my Baird mirror drum, but I have had rather bad luck with the projection lamps, which do not seem to last very long. Would it be possible to use some other type or even an arc lamp?—B.L. (London).

The probability is that you are overrunning the lamp. There is a great temptation to do this in order to get brighter pictures. If there is no tapping exactly corresponding to the voltage of the mains use a higher one—not lower. It is also important that the lamp be burnt in an upright position. The difficulty in using lamps of high voltage is that as it is necessary that the filament should be bunched so as to produce an approximate "spot" of light, arcing across the filament is liable to take place; if the filament is spaced much of the efficiency is lost. It is quite practicable to use an arc lamp under certain conditions, but in the case of your receiver the heat from this would in all probability cause the grid cell to burst. An arc lamp calls for special features of design in the entire apparatus. The life of the ordinary projector lamp should be round about one hundred hours.

An order placed with your Newsagent will ensure regular delivery of "Television."

## European Transmissions

Can you tell me if there are any television transmissions taking place other than those by the B.B.C.?—A.C. (Bath).

At the present time all continental transmissions are of an experimental nature and are not at specified times. Quite a number can be picked up, but it is impossible to say when. Zeesen appears to be the most regular and this station usually operates on Tuesday and Saturday mornings between 9 and 10 a.m. with thirty line horizontal scanning.

## Light Source for Mirror Screw

Is there any type of lamp other than the neon that can be used in conjunction with the mirror screw receiver and which will provide greater intensity of illumination?—C.D. (Bow).

There are mercury tubes specially made for this purpose which give a light which is nearly white. The Mervyn Sound and Vision Co. would send particulars of these upon application.

## Holding Motor Speed Steady

I have difficulty in holding the speed of my mirror-screw receiver using the 30-tooth wheel and synchronising coils. The A.C. supply here is time-controlled and I have two synchronous clocks which keep absolutely accurate time. Is it not possible to use this supply for motor control, and if so what number of pole pieces should I need on 50-cycle supply?—S.A.T. (Manchester).

Owing to its comparatively small diameter the mirror screw, is perhaps the most difficult type of scanner to hold at a steady speed, but you should have no difficulty in accomplishing this, using the mains for the purpose, providing that the periodicity of the mains is constant. Replace the present 30-tooth synchronising wheel with one having eight teeth and supply the coils with A.C. from the 50-cycle mains. It may be necessary to rewind the coils but you can make a test by placing an ordinary incandescent lamp in series with them as a resistance. This arrangement will give a steady speed of 750 revolutions per minute.





REVIEWS OF THE PROGRAMMES AND RECEPTION REPORTS

IN past seasons "lookers" have had an early view of coming fashions from a famous house of court dressmakers. Exquisite and expensive gowns have been displayed by mannequins before the projector to the envy of every woman present in the studio. This year the display will be given of a more popular type, but the dresses will be the last word of their kind, the mannequins will be beautiful, and I expect that feminine interest will be as keen, if not, keener, because the gowns will be within reach of many pockets.

September 14 is the date suggested, but the show may be postponed if the models are not ready in time. Several modes will be shown to the public for the first time by means of television.

\* \* \*

Programmes last month were both sad and glad. Sad because George Sanders and Pat Waddington were appearing for the last time before sailing for the United States; farewell performances are always painful occasions. Glad because there were several successful light productions and Pearl Rivers was discovered for "lookers." The producer considers this dancer a "find," and she can sing too.

George Sanders and Patrick Waddington have both appeared regularly in the programmes since the service started in the studio at Broadcasting House two years ago and we shall miss them. They are members of the younger school who were quick to recognise the value of learning the new art in its early days and they have been as successful on the stage as in the studio. Pat has gone to New York to take the lead in the undergraduate play which was at the Comedy Theatre, and George is to play a big part in the American production of Noel Coward's *Conversation Piece*.

It was "hail and farewell" to another artist, Gladys Lorimer, a

newcomer to television who is now on the way to Australia. She made a good picture in an Empire costume and her voice impressed Kneale Kelley, who came to the studio especially to hear her on the recommendation of Alan Paul, an accompanist who was also new to the studio.

Television programmes have been broadcast for so short a time that artists quickly become "veterans," and we greeted Anna Duse as an old friend when she arrived to dance in the same programme. The young dancer had not been seen in the flickering beam for a year, which seems a long time in the life of this business. Her dress for the "Can-Can" was copied from an old engraving.

A beauty queen needs to be seen

and for many listeners the appearance of Miss Radio on the stage at Olympia must have been tame. Sitting at home during the relay I was bored because I could not see her, though the audience in the theatre was audibly delighted, but when the same Kathleen Pinnick appeared in my visor I was charmed.

The producer had brought this London typist of eighteen years to the studio. Thrust into fame overnight she told what it felt like and the performance was interesting because we could also see what she looked like.

\* \* \*

Lucienne Herval was another striking figure to face the scanner last month. Generous gesture helps an artist to succeed in television. By emphasising her words with move-

=====  
*The stable companions—Jass and Jessie—are well known to television enthusiasts. A feature was made of their performance at Radiolympia.*  
 =====



ment and change of expression, this Parisien actress made a first-class picture.

It is a safe assumption that many "lookers" who use their sets at night cannot do so in the morning and programmes are worth repeating. Reminiscent material is popular on the radio, but costumes are a great aid to shows of this type.

Much of Harold Scott's impression of Grimaldi would have been lost, had it not been possible to see his wig with a tail which wagged as he sang. The make-up was complete to the blue pom-poms and black side whiskers favoured by the most famous clown of the English stage who died nearly a hundred years ago.

This made quite the best character picture of the month's programmes, but the song which I should like Harold Scott to repeat is "Tazel, Tazel, it is wonderful fun to be shot from a gun."

\* \* \*

When we hear the name Hambourg we think of the pianist, because in this country his brother, the 'cellist, is not so well known, which was in itself, a very good reason for asking Boris Hambourg to play for

"lookers." Brother of Mark, Boris is famous in Canada as 'cellist director of The Hambourg Trio and a member of the Hart House String Quartet, leading exponents of chamber music in the Dominion.

It is not easy to televise the 'cello and I think that the three-quarter picture which we saw is the best position. Wherever the instrument is placed it is difficult to get the full sweep of the bow without losing detail of the movement of the left hand on the strings. Like his brother, Boris looks a musician and his recital was entirely successful.

### For Your Diary

Maria Sandra, singer of lieder, Molly Radcliffe, classical dancer, and Maxim Turganoff will all be seen and heard on August 31 in the morning.

A repeat performance of the old-time programme, transmitted in the morning of August 10, will be broadcast at night on September 4 with the same artists; Laurie Devine, Pearl Rivers and Harold Scott.

Friday, September 7, brings Maxim Turganoff to the studio again, this time with Alexeieva, singing duets and solos. We have

missed this great little tenor who has been away in hospital for some weeks. He is now happily recovered as "lookers" will judge from his undertaking two engagements within eight days; his voice is as good as ever.

Other dates to remember are September 14 for a mannequin parade, probably; and September 18 for a repeat of "The Gods Go A-Begging" ballet with Sokolova.

Carmen will be given again in October.

## TELEVISION AT RADIOLYMPIA

Radiolympia was not in any sense a television exhibition, but it is significant that one of the stands that caused the greatest interest, and round which there was always a very large number of people, was entirely devoted to television. We refer to the Plew stand on which the three models of the latest Plew receivers were for the first time shown to the public. A description of these receivers appeared in last month's issue of this journal.

Although there was only the one complete television receiver exhibited at Olympia there were several exhibits of an associated character. Messrs. Ediswan were showing their latest cathode-ray apparatus, and the demonstrations of this attracted considerable attention. Messrs. Cossor also had a display of cathode-ray tubes.

Sound Sales, Ltd., showed time bases and exciter units for the cathode-ray tube, a description of which appears in another page in this issue. Wolsey Television, Ltd., had on view a number of television components and kits of parts amongst which was the new T.I. neon-mercury lamp, also described in this issue.

### Cathode-Ray Transmitters

This interesting application of the cathode-ray tube is being extensively investigated by several German research laboratories. The difficulties seem tremendous, but a solution is sought by means of the photocells in conjunction with cathode-ray tubes.



*Hermione Gingold in Mr. Pullpleasure's Guide. These artists also featured at Radiolympia.*



# THE LATEST GERMAN DEVELOPMENTS



*These photographs of the latest developments in Germany are the first to be released and they were specially sent by air mail in order that they could be published in this issue. A full account of German progress will appear next month.*

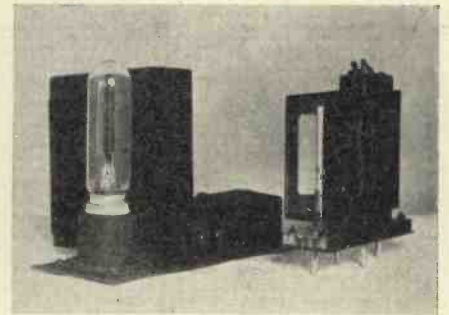

*Above (left) Fernseh A.G. 180-line spot-light transmitter with 150-amp. arc and 2½ foot disc running at 6000 revs. per minute in vacuum. (right) Tekade Kerr cell unit for 180-line mirror-screw receiver.*

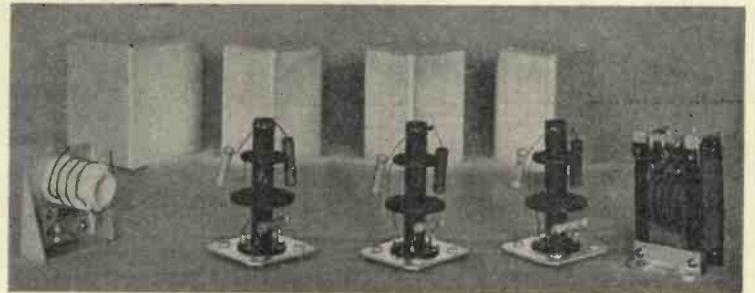

*(Left) Tekade complete ultra-short wave sound and vision receiver for 180-lines, (Above) Fernseh A.G. components of ultra-short wave kit for television, (Below) Interior of time base (Ardenne).*

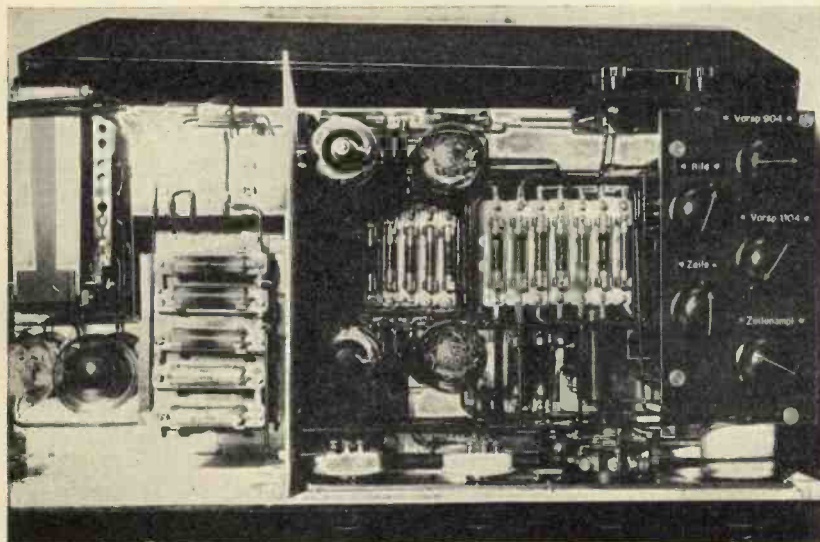

## Reception Distances of the Berlin Ultra-short Wave Transmitter.

**A**T a meeting of the German Television Society one of the Post-Office engineers, Mr. Scholz, gave an account of recent experiments carried out to ascertain the service range of the television transmitter. A super-het receiver was used.

These tests conclusively proved that buildings do not offer much obstruction to ultra-short waves and reception was possible even in narrow courtyards.



At a radius of about six kilometres, that is roughly four miles, from the Witzleben transmitter, reception was very good. At distances of seven and a half to fifteen kilometres from the tower reception was good; the length of the aerial required was less than the actual wavelength, that is less than seven metres. In Potsdam,

at a distance of about twenty kilometres, longer aeriels were required to obtain the same quality of reception, and at Brandenburg, at fifty kilometres, only a high outdoor aerial could provide adequate reception.

At ninety kilometres from the Witzleben tower even with a more

sensitive receiver and a very good aerial, the pictures were not good enough for actual service, but at a height of about fifty metres from the earth, the same quality of reception as at Brandenburg was obtained; that is to say as at fifty kilometres distance.

As far as interference was concerned, this was only experienced from the ignition systems of motor-cars. The average distance at which this was found to spoil reception was five kilometres, but in some cases ten and even fifteen kilometres.

Drawing conclusions from these tests it appears that the Berlin Witzleben ultra-short wave transmitter, which works with a power of 4 kW in the aerial, will be sufficient to provide the whole of the town with an adequate television service.

It was further stated that a well-known German firm had succeeded in producing a high frequency cable which would pass a frequency band of from zero to five hundred thousand cycles without distortion. The maximum length that could be used without intermediate amplification will, it was stated, probably be somewhere in the neighbourhood of seventy kilometres. This development is most important, as it will then be possible to link television transmitters at distances of approximately fifty miles.—A.G.

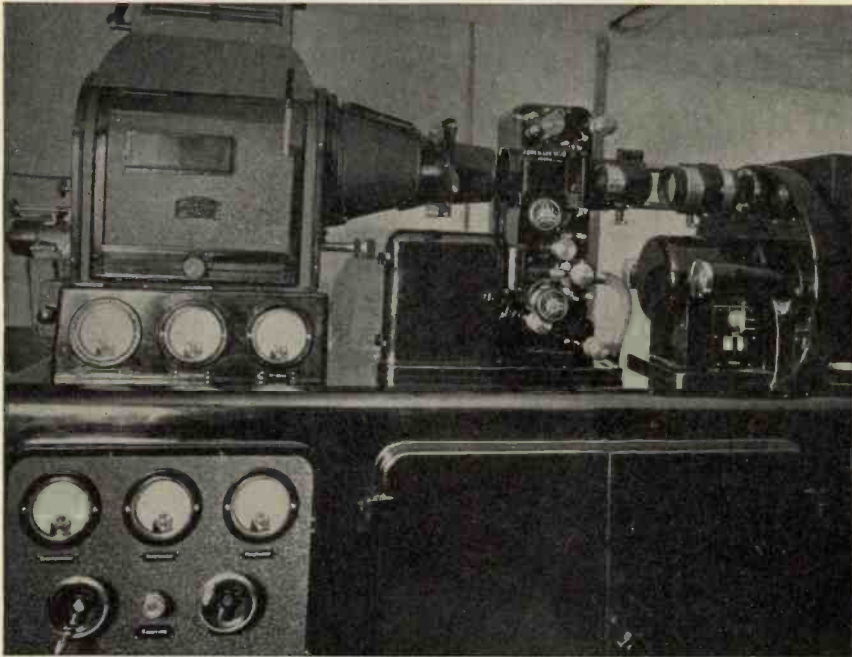

*The Fernseh A.G. 80-line sound-film transmitter supplied to the German Post Office.*

## TELEVISION IN JAPAN

THE increasing importance of Japan in commercial fields of the world has been a subject of topical interest recently. It is, therefore, interesting to visualise progressive activity in technical circles.

With the latter idea in mind, our representative set out to interview Dr. Karawada, Professor of the Engineering College in Waseda University, near Tokio, during a recent visit to this country.

Questioned about the work being done in Japan at the present time, we were interested to receive some details of the layout at the Waseda Laboratory for televising baseball matches.

The apparatus is located at a corner of the baseball pitch, behind a plate-glass screen, and it is possible to follow two or three of the players with a telephoto lens. A scanner on the Nipkow disc principle is employed, using sixty lines and framing eighteen pictures per second. The wavelength used is 159 metres with a power of

about twenty watts in the aerial. The definition leaves something to be desired, but satisfactory results are obtained in conjunction with a running commentary.

Six stages of amplification have been employed in conjunction with a Kerr cell and mirror-wheel projection apparatus. A new mirror-wheel equipment is in course of construction, and actually two wheels will be used simultaneously, one each for vertical and horizontal scanning respectively. The wheels will run at 6,000 revolutions per minute, and an increase to 120-line scanning will be made. The light will be produced by a 10 kW arc.

It is interesting to note that the Waseda University Laboratory specialises on Kerr cell reception, whilst the cathode-ray principle is being explored at the Technical College at Hamamatsu, about 100 miles from Tokio.

The other experimental centre is at the Electro-technical Laboratory of the Ministry of Communications, Tokio,

where neon, sodium, mercury lamps, etc., form the subject of investigation for television purposes.

It appears that there is little to choose to date between the various methods of reception, at least as far as definition is concerned, although, of course, there is the difference between a projected and subjective picture. Dr. Karawada is of opinion that the more important trend of progress for the near future will lie in the large projected picture for public functions.

The three television authorities mentioned above are subsidised by the Broadcasting Corporation of Japan, which holds a monopoly. Thus the joint research workers pool their findings for the benefit of their national broadcasting authority.

Professor Karawada stated that he was especially impressed with the German transmissions and reception, utilising the intermediate film with 180 lines on a wavelength of 7 metres, and so far as this country is concerned with the potentialities in the latest investigations of the Marconi Company.





# Correspondence

Correspondence is invited. The Editor does not necessarily agree with views expressed by readers which are published on this page.

**Armature Interference**    ::    **Another Amateur Offer**  
**Co-operation Wanted**    ::    **Flicker**

### Armature Interference on Scanning Disc

SIR,  
 I own a disc receiver driven by a universal motor—A.C.—and I find that by connecting a 2 m.f. condenser across the motor terminals practically all armature interference is obliterated.

This, I hope, may be of some interest to readers who suffer from this complaint on their scanning discs.

CHAS. W. GLOVER (Liverpool).

\* \* \*

### Another Amateur Offer

SIR,  
 I am pleased to have found time to take up television and commence experiments. Until recently I have really been too busy with other experiments to spare time for television, but by sacrificing a few hours per week from my experiments on short-wave transmission and reception I have managed to put a few hours per week away for the obviously coming phase in wireless—television. I realise what a future it obviously has, hence my interest has been timely aroused.

Like Mr. R. K. Shennfold, in his letter in your August issue, I myself have spent a great deal of time and money in maintaining an up-to-date efficient short-wave transmitting and receiving station. I work C.W. and phone on all frequencies from 56 mc. to 1.7 mc. In fact I have spent some 14 years and over £500 on test apparatus, with a present layout of £200 on transmitting and receiving apparatus.

Television experiments bring a further burden in layout, expenses, etc. With the little encouragement given at the present time, without local co-operation, transmitting experiments would hardly be worth while.

Now I would appreciate information from any local interested persons regarding transmission that I might carry out. Unless I can be

assured of definite co-operation such transmission would be useless and not worth the expense.

I would willingly share my transmitting room with any interested television experimenters and permit apparatus to be brought, built, or tested.

Re Mr. C. C. Miles' August letter. May I inform Mr. Miles and others interested, that the Radio Society of Great Britain and British Empire Radio Union, 53 Victoria Street, London, S.W.1, have formed a R.E.S. (research and experimental section) which includes a television section, of which I am a member.

This section consists of television enthusiasts, beginners and otherwise, who have combined to bring television to the fore.

I would welcome correspondence on any radio experiments from any persons interested.

H. JONES, G5ZT, M.R.S.G.B.,  
 etc. (Preston, Lancs.).

\* \* \*

### Co-operation Wanted

SIR,  
 Your editorial in the August issue of the now excellent TELEVISION includes a proposal which I think should meet with the approval of all television experimenters.

Apart from two, apparently, elementary patents which I have obtained I am afraid I have little to offer in the way of practical help, unless a transmitting licence could be obtained to pursue investigations on the above patents.

I have had five years' intensive practical experience in the development of audio-cinematic projection and at the moment am conducting minor experiments in television at home.

Should your scheme show signs of maturing I shall be only too pleased to co-operate with others in the foundation of an amateur society.

Thanking you for this suggestion,

which, I am sure, under your patronage, will meet with every success.

H.F.H. (Norbury).

\* \* \*

### "The Multi-spiral Scanning Disc"

SIR,  
 It is true, that Sanabria's multi-spiral scanning disc, described and first published in his U.S. Specification No. 1,805,848, is anticipated substantially by Mr. Baird's Specifications Nos. 321,389 and 314,591, cited in a letter of your issue of August, 1934.

But, so far as I am aware, all these multi-spiral scanning methods, especially for use in television in colours, were known twenty years ago!

I may call your attention on the German Specification No. 172,367 (August 20, 1904) and the British Patent No. 30,188/1909, dated December 24, 1908, where the same method is distinctly exemplified. I myself do not believe that these inventors have had any knowledge of the advantages of these systems, especially regarding the frequency band needed, as is pointed out by Mr. Gardiner in his article; I also have not heard of any demonstrations in connection with these old systems. I may add, that the chief characteristic feature of Sanabria's multi-spiral disc, which in producing the image scans its field in rows not adjacent each other, is likewise anticipated by the method and scanning disc described in British Patent No. 299,973 (May 21, 1927).

ROBERT F. ROSENFELDER  
 (Frankfurt).

\* \* \*

### Flicker

SIR,  
 I have read Mr. J. Sieger's letter in this month's TELEVISION re the short article on "Flicker" in the July issue, also J.H.R.'s reply to Mr. Sieger, which seems to me just a repetition of his very original but quite impossible idea.

I would be very interested to know how J.H.R. proposes covering up the whole of a television image, even momentarily, considering that no television system ever produces a whole image. So how does one cover the whole of a thing when one never possesses more than .000476 of the whole, as in the case of a thirty-line television picture? Perhaps J.H.R. will elucidate further.

ROBERT DESMOND (Wembley).



## Flicker :: An Amateur's Transmitter and Receiver :: Television Reception in Berlin

## Flicker

SIR,

May I make an observation on the subject of flicker? Your contributor J.H.R. states that flicker could be eliminated by a periodic masking of the image as a whole. Now this is clearly an impossibility with any system of television using discontinuous scanning. It has been discovered, however, that stroboscopic effects can be obtained by subjecting the optic nerves to a series of rapid shocks. This may be done by holding a tuning fork in contact with the head. It may thus be possible to obtain an apparent masking of the image as a whole by such means, the phenomenon of persistence of vision being due to chemical action in the retina itself, while the tuning fork only affects the nerve conveying the sensation of light to the brain, or at least so it would appear. It would at any rate be worth while making some experiments on this point. A tuning fork of a low pitch would be preferable, although the exact value would not seem to be of importance as the image does not exist as a whole except on the retina.

O. J. RUSSELL (Norwich).

## An Amateur's Transmitter and Receiver

SIR,

I enclose a couple of photographs of my complete outfit.

As the room is only 12 ft. 6 in. you will appreciate the cramped conditions and the difficulty of obtaining good pictures.

The first photograph shows the transmitting side. The box above the H.T. batteries is the "A" amplifier, in four stages. The H.T.'s supply photo-cell, 1st valve H.T., and other H.T.'s all separately. The photo-cell mounting is on the amplifier—hence the structure, on the left, just off the picture.

Scanning is by the drum, using a Pointolite. The 2-stage amplifier shown takes care of synchronising. The transformer supplies motor and lamp at 100 volts.

The second photograph is of the receiver. The Baird projector is fed by the 3-stage amplifier shown. The leads run through earthed flexible gas-piping. The screen is "broken away" literally, as I thought it might foul the view.

There is nothing extraordinary about the outfit; any schoolboy could have constructed it.

I use only one photo-cell and R.C. coupled amplifiers everywhere.

The scanning beam passes behind the copper-boxed, "A" amplifier, to whoever stands in the doorway (that is how tight for room I am!), and the "object" is reproduced on the



These two photographs show Mr. R. H. Parkinson's transmitter and receiver described in the accompanying letter.

screen. This arrangement is very convenient as I can stand, and be scanned, and see myself on the screen!

It is not perfect, of course, various details require redesigning, but I think I shall design it for 90-lines, but the subject, I am afraid, will have to stand across the landing and in the bathroom!

I am sorry that I cannot include photographs of earnest, bespectacled, high-browed, young men, as seems usual, but I am strictly "solo," and have been since 1924.

This really shows how easy it all is for an amateur station to transmit television, but I see from my pass-book that about £80 was spent messing with this lot of gear in the last 12 months! And now—no transmissions!

R. H. PARKINSON (Derby).

## Television Reception in Berlin

Since the introduction of television transmissions on ultra-short waves, the following matters have had to be investigated:—

1. Is the power of the television transmitter installed in Witzleben sufficient to serve the whole of Berlin?
2. Are some difficulties to be expected with regard to reception?

3. Interference?

4. Under what conditions, and at what distance will reception be most satisfactory?

Although experiments with regard to the transmission on ultra-short waves have been carried out before in Germany and in other countries the results have not been consistent, and the transmission power was com-

paratively small. The operating conditions of the new transmitters, with a power of 16 kilowatts, on a wavelength of 6.985 metres, have been somewhat different, and they required further investigation.

The experiments have been carried out by means of a television receiver installed in a motor car, and reception tests have been made chiefly at such places where one would theoretically expect the worst possible conditions. Ninety lines, with 10,800 picture points, at 25 frames per second were used, and the results were as follows:

Within a radius of 15 kilometres small aerials were sufficient for satisfactory reception, using a receiver of medium sensitivity.

Within a radius of 15 to 20 kilometres, it was sometimes necessary to install a small outside aerial. It was found possible to obtain satisfactory results with the types of aerials which every broadcasting subscriber should be able to install without any difficulty.

With regard to interference, reception was spoilt only by the ignition systems of motor cars.

The experiments conclusively showed that the range of the ultra-short wave television transmitter can be increased with:—

1. Increased height of aerial.
2. Increased power.
3. Increased wavelength (within the ultra-short wave range, of course).





# PETO-SCOTT



Est.

## FIRST WITH EVERYTHING NEW IN

1919

# TELEVISION EXHIBITED AT OLYMPIA

PETO-SCOTT will again be FIRST in giving IMMEDIATE DELIVERY to enthusiasts everywhere of the many new and interesting Television developments that were a feature of Radiolympia this year. Old customers will need no introduction to our famous and popular system of postal trading for CASH, C.O.D., or H.P. New customers can order with confidence in the knowledge that behind the name of PETO-SCOTT, Pioneers in Radio and Television, lie 15 years of service that has given satisfaction and earned appreciation all over the World. See the latest in Television at Radiolympia, and let Peto-Scott supply you IMMEDIATELY with those things you want. Nowhere else will you obtain such prompt execution of your order, lower prices, or easier terms.

**TRADE NOTE**  
Traders are cordially invited to send us their orders for TELEVISION APPARATUS for execution at usual Trade Discounts.

### PETO-SCOTT

#### SYNCHRONISING GEAR KIT



DESIGNED by one of the foremost Television Technicians and constructed of specially selected materials to ensure perfect synchronising, thereby reducing floating images to a minimum. Complete kit of parts comprises one Mild Steel frame with end bobbin supports. Slotted to permit of precise adjustment of pole pieces, 2 assembled laminated pole pieces, 2 ready wound bobbins, 2 ebonite handles for ease of control. Easily assembled at home, no skill required. Ready to mount on either end of Peto-Scott Universal Motor. Complete Kit and 7 Monthly payments of 5/- Cash or C.O.D. Post free. 37/6

Yours for 5/- and 7 Monthly payments of 5/-

### PETO-SCOTT TELEVISION LENSES

PETO-SCOTT Television Lenses are produced for Peto-Scott by one of Britain's leading lens manufacturers, Guaranteed of high optical accuracy, ensuring undistorted magnification of image.

4" Bi-convex Lens for Disc Receiver Set	5 6
6" Bi-convex Lens for Disc Receiver Set	13 6
1 pair Matched Bi-convex lenses (2" and 4") or Disc Receiver Sets	8 0

All types are stocked, and any individual requirements can be supplied on application.

### PETO-SCOTT UNIVERSAL MOTOR RESISTANCES

#### Baseboard Fixed Type

A UNIVERSAL resistance for controlling Television Motors on either A.C. or D.C. from 200 to 240 volts. Fixed Type (Baseboard Mounting). Accurately wound on porcelain air-cored former to a total resistance of 1,600 ohms, tapped at 600, plus 250, plus 150, plus 150, plus 150, plus 150 ohms; carrying capacity, 0.25 amps. at 240 volts without overheating.

#### Variable Type (Panel Mounting)

A perfect, variable controlling resistance wound to 150 ohms and carrying safely 0.25 amps without overheating. Smooth action and perfectly continuous contact over whole winding ensures the delicate control vital to easy adjustment of correct speed. Both the fixed and variable types are required to secure perfect voltage regulation. Cash or C.O.D. Per Pair. Post free. 11/6

### PETO-SCOTT SCANNING DISCS

EACH disc is of light gauge aluminium, dull black one side, and centres cut out to reduce weight. The centre-boss is an 8-ribbed black bakelite moulding. Each rib being faced white to give true stroboscopic effect, and thereby visual speed indication. A heavy-brass bush insert with grub screw provide simple & accurate fixing for 1/2 in. motor spindles. Scanning holes perfectly punched to secure uniform scanning without preventable lines. Made in 2 sizes and ready for immediate use. 7/6

16 in. diam.	7/6
20 in. diam., 12/6. (Postage, 9d. extra.)	



## MIRROR DRUM RECEIVER

COMPLETE KIT as detailed below

Cash or C.O.D. £10 : 0 : 0  
Carriage Paid  
Or 12 monthly payments of 18/3

2 Peto-Scott 3-ply wood screens for sides, 18" x 17" and 18" x 12"	2 6
1 Peto-Scott Wooden Baseboard, 12" x 17" x 1", with ebonite and wood terminal strip as specified	4 0
1 Peto-Scott Ground Glass Screen 8" x 4"	2 6
Peto-Scott Aluminium, 1/2" x 1/2" angle strip, ready drilled and cut to sizes specified	6 6
1 B.T.S. Universal, Ball Bearing Motor and Stand	1 17 6
1 B.T.S. Synchronising Gear	1 7 6
1 B.T.S. Fixed Resistance	6 6
1 B.T.S. Variable resistance	5 6
1 Mervyn Mirror Drum Kit	2 15 0
1 W.B. Horizontal Mounting 4-pin Valveholder	1 0
1 Sanders Set of Optical Instruments, including: 1 Adjustable Aperture, 1 Lens and Holder, 2 Angle Mirrors, less slide rails for Aperture	2 2 6
6 Belling Lee Type "B" Terminals	3 0
3 Bulgin Single-pole On-Off Toggle Switches, S.80T	3 9
Quikon Wire, screws, 2 doz. bolts and nuts, washers, flex, etc., and 2 wooden blocks, 3" x 1" x 1"	2 3

Complete Kit, Cash or C.O.D. Carriage Paid £10 0 0  
If G.E.C. Mercury Vapour Recording Tube is required with above kit, add £3/10/- to Cash or C.O.D. price or 6/6 to each monthly payment.

\* Any of the above items supplied separately, CASH or C.O.D.

## PETO-SCOTT UNIVERSAL TELEVISION MOTOR

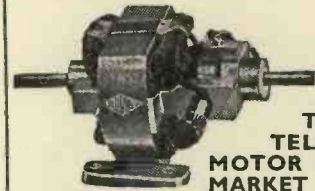

THE BEST TELEVISION MOTOR ON THE MARKET

SPECIALLY designed for Television and built to stand hard usage, yet runs with the perfect precision so essential to Television. 1/2" diam. spindle extended 1 1/2" each side. Each end bearing screwed for synchronising gear. Heavy cast aluminium frame ensures freedom from vibration and noise. Self-oiling bearings provide even running. Armature and field coils accurately wound. Absolutely Universal for A.C. or D.C. Mains, 200-240 volts and A.C. 40 to 60 cycles. Cash or C.O.D. Post free, 30/-, 6-volt (Battery Type), 35/- All models with stand, 2/6 extra.

Yours for 5/- and 6 monthly payments of 4/9.

IMPORTANT.—Miscellaneous Television Components, Parts, Kits, or Accessories for Cash, C.O.D. or H.P. on our own system of easy payments. Send us a list of your wants. We will quote you by return. C.O.D. orders value over 10/- sent carriage and post charges paid (GREAT BRITAIN ONLY). OVERSEAS CUSTOMERS CAN SEND TO US WITH CONFIDENCE. We carry a special export staff and save all delay. We pay half-carriage—packed free. Send full value, plus sufficient for half-carriage. Any surplus refunded. Hire Purchase Terms are NOT available to Irish or Overseas customers.

## PETO-SCOTT 75/- DISC TELEVISION KIT

ASSEMBLED IN 30 MINUTES

Peto-Scott, Pioneers in Television since 1927, have, after considerable research, produced this "up-to-the-minute" Disc Television Receiver Kit, of which Efficiency and Economy are the keystones. Peto-Scott's huge production resources, coupled with their Easy Way System, put this splendid Kit within the reach of all.

NO SPECIAL TOOLS REQUIRED

Designed to work from any 3-valve battery or mains set, the Peto-Scott 75/- Disc Television Receiver is supplied in Kit form, and comprises Peto-Scott Universal Television Motor and stand; controlling resistances; laminated and ready assembled chassis; Stroboscopic 16" scanning disc; Lens and lensholder; Neon Lamp and holder, together with sundry small parts. It is absolutely complete down to the last screw and piece of wire. Full-size Blueprint with assembly, wiring and operating instructions included with every Kit. Cash or C.O.D., Carriage Paid, 75/-.

YOURS FOR

# 15/-

and 11 monthly payments of 6/3.



PETO-SCOTT CO., LTD., 77, CITY ROAD, LONDON, E.C.1  
West End Showrooms: 62, High Holborn, W.C.1.

Tel.: Clerkenwell 9406/7  
Tel.: Holborn 3248.

Dear Sirs

(a) Please send me .....

(b) I enclose Cash/Deposit .....

NAME .....

ADDRESS .....

Please send me your TELEVISION LISTS

T.9/34.

# IMMEDIATE DELIVERY—CASH—C.O.D. or H.P.



## IMPROVEMENTS IN CATHODE-RAY TUBES

*Intensive research work is being carried out on the cathode-ray tube, and as a consequence improvements are constantly being made. In this article G. Parr outlines some of the more important and recent developments.*

THE majority of cathode-ray tubes in use for television and experimental work generally are of the low or medium voltage type, in which the accelerating voltage for the electron beam seldom exceeds 2,000 volts. The focusing of the electron stream produced by the cathode is carried out by a combination of negative voltage applied to

gated by von Ardenne (Proc. I.R.E., Vol. 20, p. 1,310), who has taken some remarkable photographs of the path of the electron stream on its way to the anode. The drawing of Fig. 1, adapted from his paper, gives a clear idea of the action of the negatively charged shield surrounding the cathode.

### Concentrating the Beam

On their way up the tube, however, the electrons tend to diverge owing to mutual repulsion between similarly charged particles, and hence the concentrating action of the negative cylinder is not sufficient by itself to ensure a sharply defined fluorescent spot. The introduction of a small quantity of gas into the tube serves to maintain the compactness of the electron jet and ensures a sharply focused spot. The action of the gas can briefly be described as follows:

As the stream of electrons proceeds along the tube some of them collide with the molecules of gas and produce positive ions by their impact. These positive ions are comparatively slow moving and therefore tend to "hang about" in the path of the beam. After a short time a point is reached when the jet contains a large number of positive ions distributed along its length, the colliding electrons having moved on. The beam now has a positively charged core which exerts an attraction on the electrons moving along it and tends to keep them from diverging on their way up the tube.

### Threshold Effect

The presence of gas in the tube, while useful as a means of maintaining sharp focus, unfortunately brings one or two disadvantages in its train. The one which has been noticed by all experimenters with cathode-ray tubes, and which has been previously described in this Journal (January, 1934, p. 9) is that known as "Threshold Effect" or "Origin Distortion."

The presence of positive ions in the space between the deflector plates necessitates a certain minimum poten-

tial to be applied to them to neutralise their charge before the beam can be deflected. This potential varies, but can reach as high a value as 10 volts. In effect, the beam does not respond uniformly to a deflecting potential on the plates when it falls below this value. In practice this non-uniformity can be allowed for, but in television work it is irritating in its effect on the picture, and the higher the definition the more obvious it becomes.

The second disadvantage of the gas-focused tube is that a definite short time is required for the electrons in the beam to produce sufficient ions to exert a focusing effect.

If the beam is deflected, the process of ionising will have to commence all over again, as the ions will not follow the movement of the beam sufficiently rapidly. This means that a rapid movement of the beam tends to make it lose focus, and this point is of prime importance in high-definition work where the beam is deflected at the rate of hundreds of kilometres per second.

Another phenomenon which is met in gas-focused tubes is that of "ionic oscillation." When a television screen is formed on the end of the tube the lines sometimes appear to be broken up in a tiny ripple formation as though a small signal had been applied to one of the deflecting plates. The same effect is sometimes produced by a heterodyne whistle on the actual television receiver, and according to von Ardenne the frequency is of the order of 50,000 cycles. The cure for the trouble is the fitting of a metal shield round the outside of the tube in the region of the deflector plates, the metal being connected to the anode of the tube. This has the effect of removing stray charges from the walls of the tube, which act on the beam. A sheet of tinfoil wrapped tightly round and wired to the anode pin makes a very efficient shield.

### New Developments

The gas-focused tube, although cheap and easily controlled, will not

*(Continued on page 420.)*

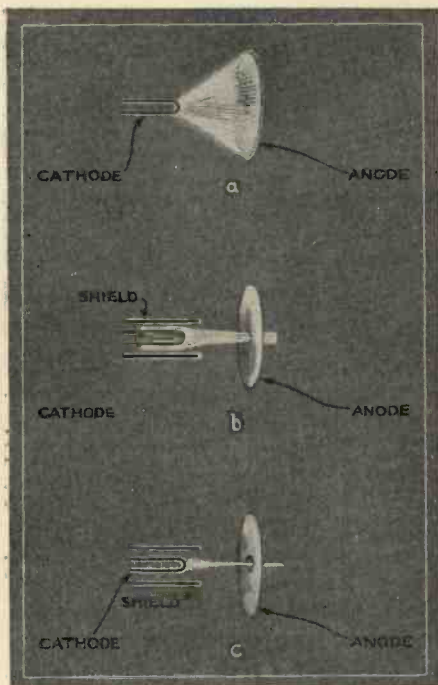

Fig. 1.—Shows the path of the electrons through the accelerator of the C.R. tube, and the effect of the negative cylinder on the beam. (a) no cylinder; (b) small negative bias; (c) normal focusing bias.

the shield surrounding the cathode, and by the action of a trace of inert gas in the tube itself.

The electrons emitted by the cathode, as might be imagined, spread out in all directions and arrive at the anode or accelerating electrode in the form of a "spray." If, however, the cathode is surrounded by a cylinder to which a negative potential is applied, the electrons will be repelled by the negative charge and will flow to the anode in the form of a compact jet of such a size that the majority of them will pass through the hole in the anode and hit the fluorescent screen. The behaviour of the electron stream has been investi-





# NEGATIVE TO POSITIVE PICTURE AT WILL

The television experimenter is often faced with the problem of converting his pictures from negative to positive. There are several ways of doing this, but they all take time to carry out, and even then you will still be faced with the problem of overload distortion, always apparent when a triode detector is used.

The use of the new WX6 Westector, however, enables you to overcome both difficulties. It is an H.F. metal rectifier designed for linear detection, requires neither H.T. nor L.T., and used as directed, it cannot overload; it cannot give harmonic or phase distortion, and it cannot deteriorate or break down.

No matter what your set, you can be sure of a definite positive picture with a Westector as the detector. The Westector should be mounted in a grid leak holder. Then, if your test picture happens to be negative, just pull out the Westector, reverse it, and your picture will be 100 per cent. positive; remaining so, until further experiments may alter it.

The two theoretical circuits shown above show how easy it is to convert to metal detection. Fig. 1 shows a typical 5-valve superheterodyne receiver for use on A.C. Mains. Anode bend detection is employed.

Fig. 2 shows the same set converted to metal detection using a WX6 Westector. Notice how simple is the change, and the efficient manner in which A.V.C. is obtained.

These circuits are merely typical, and are not intended to be used as designs for receivers. They simply illustrate how the WX6 Westector may be incorporated in a receiver to give straight line rectification, and consequently better and "all positive" pictures.

Full particulars may be obtained from:—

**The Westinghouse Brake & Saxby Signal Co., Ltd., 82, York Road, Kings Cross, London, N.I.**

Half-wave, maximum input voltage: 36 volt peak carrier, maximum current output 0.12 milliamps.

**WX6 WESTECTOR**

PRICE

**7/6**

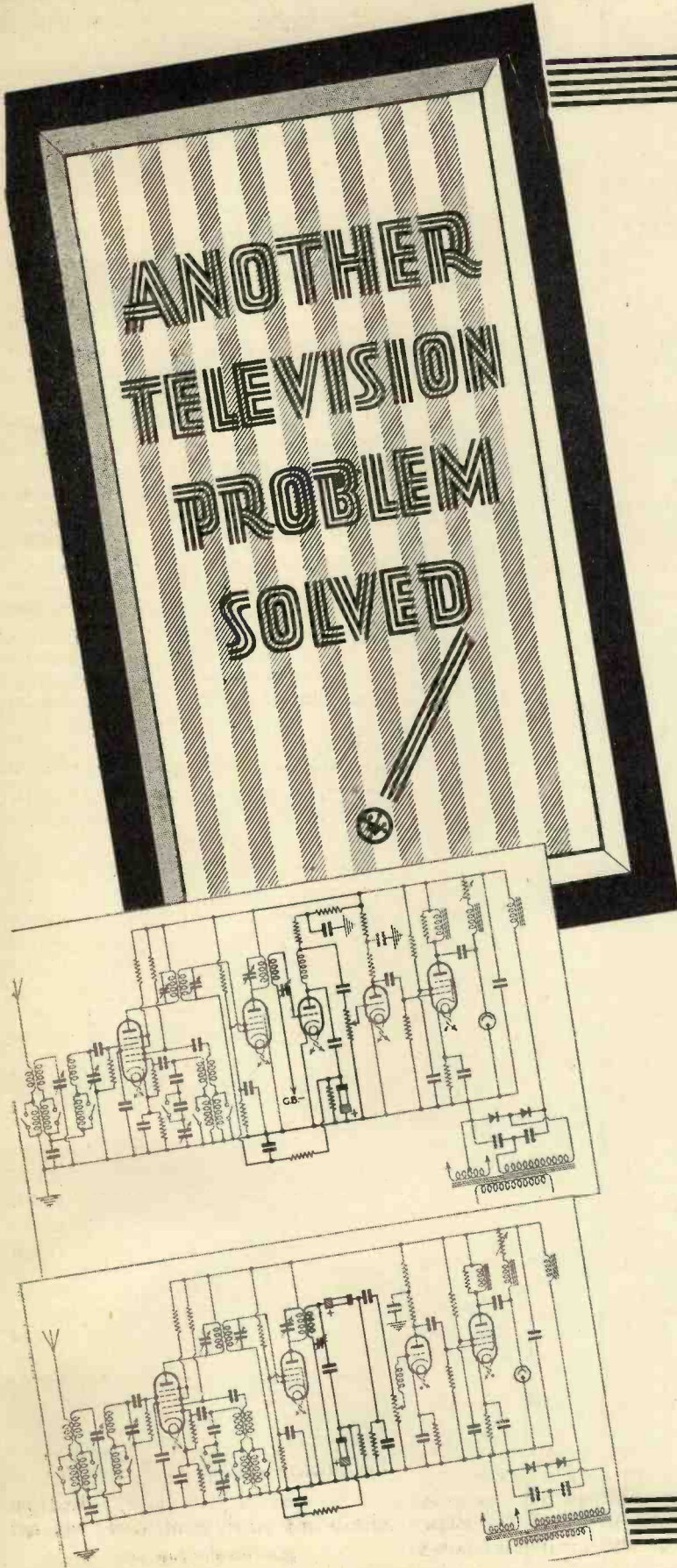

When replying to advertisements, please mention "Television"

be the best method of producing high-definition television images.

To make the cathode-ray tube entirely satisfactory for this purpose, other means of focusing the beam would have to be used, and it is in

electron stream can be considered to be refracted in the same way that a beam of light is refracted at the surface of a glass lens. For a particular geometric construction of the two accelerating

constant over a wide range of values. The final focusing is helped by adjustment of the negative shield potential as in the gas-focused tube. The deflector plates are mounted beyond the second accelerator, and act on the beam as it emerges from the cylinder (Fig. 3).

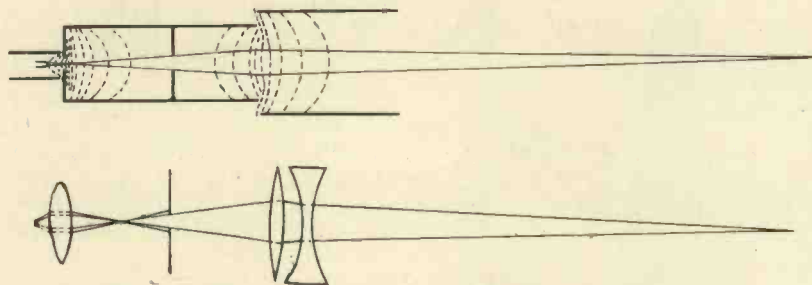

Fig. 2.—The analogy between electronic focusing and optical focusing by lens system.

this direction that research is proceeding.

In the latest type of tube the vacuum is high, comparable with that of the thermionic valve, and the focusing of the beam is accomplished by electrostatic fields.

The fact that a beam of electrons could be focused by means of a magnetic field has been known for a considerable time, and in fact cathode-ray tubes of the high-voltage pattern (50,000 v.) use magnetic coils for focusing the beam.

The use of electrostatic fields for performing the same function has been recently investigated by Zworykin (Journal of the Franklin Institute, May, 1933, p. 535) and he has evolved a complete analogy between the action of electrically charged cylinders on the electron stream and the action of lenses on a beam of light; in fact the subject is referred to as "Electron Optics."

In the electrostatically focused cathode-ray tube, the beam is first accelerated by an anode placed near the cathode as in the case of the "soft" tube, but after leaving this anode the beam is passed through a second cylindrical anode at a higher potential than the first. The electrostatic field in the second cylinder causes the electron stream to converge towards the axis of the tube and by varying the potential the beam can be brought to a focus on the screen.

The diagram of Fig. 2 shows the action of the electrostatic field and the very close analogy between this and the action of a lens system. The "lines of force" of the field are shown by the dotted lines, and the

electrodes there is a definite proportion between the potentials, which is

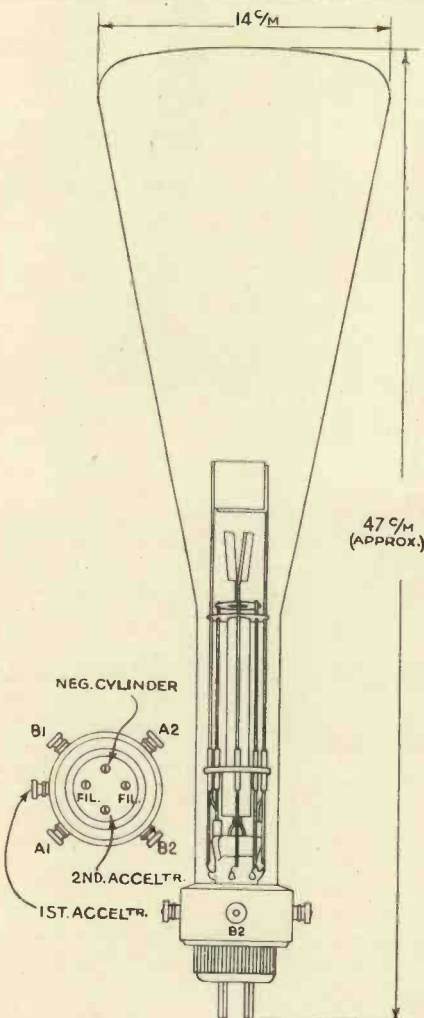

Fig. 3.—Diagram of hard C.R. tube showing second accelerator electrode and deflector plates.

Suitable placing of the focusing electrodes enables the actual image of the source of electrons to be projected on the fluorescent screen in the same way that the image of the filament of a lamp can be projected through a lens system.

The electrostatically focused tube removes all the disadvantages attending the use of gas in the tube and introduces very little extra complication. The potential for the second accelerator can be obtained from an H.T. rectifier unit in a similar manner to that previously described (TELEVISION, June, 1934, p. 274) and since the current taken is negligible no elaborate smoothing is required. This new tube represents an important advance in the technique of cathode-ray television, and it is interesting to note that a tube developed by the Edison Swan Co. was on show at the Radio Exhibition.

## Sensitive Photo Relay

G. M. Laboratories Incorporated, 1731 Belmont Avenue, Chicago, announce a new photo-electric relay, capable of operating at greatly increased distances. This type of relay will operate reliably on changes of illumination as small as one foot candle, or less, and when used in conjunction with the G.M. No. 1217 light source, can be operated at a distance of 90 feet with a white light, and up to 40 feet with an infra-red beam.

With this new unit a speed of 600 operations per minute can be consistently maintained. The circuit can be so arranged that no plate current is drawn from the amplifier valve except while the light beam is interrupted, thus increasing the life of the valve.

## De Forest Promises \$200 Television Sets

Dr. Lee de Forest, pioneer radio inventor of Los Angeles, declared recently that television sets will be marketed at 200 to 250 dollars, next year.



# Osram

**GASFILLED RELAY TYPE G.T.1.**  
For Television Receivers  
MADE IN ENGLAND



**NOW REDUCED IN PRICE**

Old Price	NEW PRICE
50/-	40/-

**Improved Characteristics**

Peak current increased to:—  
1.0 amperes.

This means still greater reliability.

**REDUCED IN PRICE  
IMPROVED IN QUALITY.**

Advt. of The General Electric Co. Ltd., Magnet House, Kingsway, London, W.C.2.

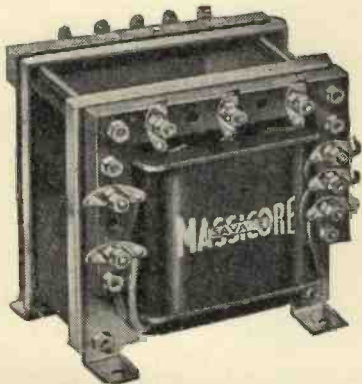

## W. BRYAN SAVAGE the mains transformer specialist

offers . . . mains transformers of unimpeachable efficiency and reliability at really moderate prices. Designed on the most advanced principles, triple-tested (300 per cent. over voltage and interwinding tests) and guaranteed, Savage "Massicore" transformers have earned a reputation second to none among radio experimenters. Send to-day for price and specification list No. T.2.

# SAVAGE

Extra special service on non-standard specifications. Send details for quotation

W. BRYAN SAVAGE, 56/58, CLERKENWELL ROAD, LONDON, E.C.1.

# NEW LINES

By **BELLING-LEE**

**Standard Disturbance Suppressor 1118**



This is all that is required in 80% of cases. Type 1118. 10/6



For Small un-earthed electric motors. Type 1171 .. 8/6



**Flashing Sign Suppressor**  
Type 1172. 11/6



**Neon Sign Suppressor**  
Type 1142 £3/15/-

**D.C. Ripple Suppressor**

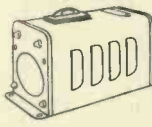

For use when 'hum' on D.C. mains is troublesome, such as when fed from Mercury Arc Rectifiers. Type 1140 £3/7/6

**Car Radio Interference Suppression Kit**



6 cylinder 20/-  
4 cylinder 15/6



**CONTACT SUPPRESSOR**

Type 1144. 2/6

**PICK-UP. Model D.**



Without volume control 30/-

A description of the methods evolved by the Post Office and by engineers throughout the world for the suppression of electrical interferences with Radio reception and including results of research work conducted by Belling & Lee, Ltd., with 37 illustrations. From your Radio dealer, price 6d. or post free 6d. by sending the coupon.

**WRITE FOR BOOKS**

**BELLING & LEE LTD**  
CAMBRIDGE ARTERIAL ROAD, ENFIELD, MIDD.

Please send (a) Free Catalogue, (b) 6d. Book. Stamps enclosed.

Name .....

Address .....

..... Tel. Sep.

**OLYMPIA STAND No. 41**

**VOLTAGE ADJUSTER**



Use practically any make or combination of universal valves on any mains supply without the use of additional resistances. Type 1173. 17/6

**PLUG TOP VALVE Connectors**



Type 1175 .. 1d.



Type 1167 .. 2d.



Type 1156 .. 4d. (shrouded)



Type 1166 .. 8d. (shielded)



**AIR FORCE Wanderplug**

will not come out Type 1157 each 1/-



**TELEVISION LETTERINGS**

Syn. Mod. Anode GN. X1, X2, Y1, Y2, A1, A2, B1, B2

**VALVE HOLDERS**



Type 1163 8d.  
" 1164 10d.



Type 1135/S  
4 way ... 4d.  
Type 1136/S  
5 way ... 4d.  
Type 1138  
7 way ... 5d.  
Type 1137  
9 way ... 6d.

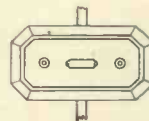

**Double Choke and Condenser Unit**

3 to 30 amps. From £3/10/-

There is news in the "Television" advertisements



The T.I. neon-mercury lamp.

WE have received from Television Instruments, Ltd., a sample of a new high-intensity gas discharge lamp which has been specially developed for television purposes. The features of this lamp will be clear from the photograph

## A NEW NEON MERCURY LAMP

and it will be seen that it consists of a coiled glass tube fitted with tubular electrodes. The filling is a mixture of neon and mercury. The lamp is intended to be viewed with the tube convolution at right angles to the plane of vision and in this way an intense and almost even field of light is obtained. This lamp may be used for all purposes where utmost brilliancy of small area combined with sensitivity to modulation by high frequencies is desired. The approximate efficiency is .33 watt per candle power. The design of the T.I. lamp permits the use of a reflector behind the point of maximum intensity. This important advantage results in considerably more light at the plane of observation.

The T.I. lamp will strike at an unusually low voltage considering its efficiency. If, however, it is required to strike upon a known deficiency of voltage the difficulty may be surmounted by superimposing a momentary surge voltage across the terminals from a charged condenser. A

quicker method may be found by lightly grasping the centre of the tube in the hand for a second or two. Unless the supply is unreasonably deficient it will generally be found that the peaks or surges caused by the output modulator will be sufficient to cause the lamp to strike. The polarity of the voltage applied is immaterial.

It is claimed that the T.I. lamp is conveniently adaptable to all known systems where modulated lamps are needed, some examples being rotary mirror-drum, stationary mirror-drum, oscillatory mirror, mirror-screw, Jenkins prismatic discs, lensed discs, lensed drums, Nipkow discs, either for direct viewing or projection on translucent screens.

A brief test of the lamp showed that it gave an excellent and even field of illumination. At a later date we hope to give a report of a test upon an actual transmission. The address of the manufacturers is 323 City Road, London, E.C.1, and the price 25s.

## I WATCH A REHEARSAL

By Whitaker-Wilson

RECENTLY I sat in Eustace Robb's private room and watched a rehearsal of a show to be transmitted that night. It so happened that Gus Chevalier was in the cast. Unfortunate in a way because the engineers could hardly do their work for laughing at him. He kept us in yells of laughter.

If I can describe what he did I think it will serve to show what television is to broadcasting, and also what we miss without it. That television is wonderful goes without saying but apart from the cleverness of it as an invention it set me thinking.

Here is a simple example of the help it provides. You and I have long since become accustomed to taking in things through the ear alone. So long as the effects are not allowed to interfere with a play too much we find them agreeable.

Also, looking at it from the other side of the microphone, all broad-

casters know that unless they convey everything in the tone of their voices their hour is lost so far as listeners are concerned. The same applies to writing plays. Unless you convey everything in the line . . . well you understand what I mean.

*With television there is the added power of personal appearance and of gesture.*

We do everything by thought-association. When we go to a theatre we expect both to see and hear. When we listen to wireless we expect to hear only. *When we watch television the pull of the wireless idea in our minds is so strong that we are taken by surprise because there is gesticulation and an appearance of the broadcaster.*

The screen on the receiver in Mr. Robb's room shows a picture measuring 6 in. by 14 in., which is larger than the ordinary commercial set size—about 7 in. by 3 in. I suppose

the nearest thing to it is a film, but nothing really reminded me of a film even though the effect is really much the same because a man spoke, sang, and acted. No! there is something about television that keeps it apart from anything else we have of the kind.

Perhaps it is the knowledge that, in a film, one is looking at a series of photographs of something which happened in the past, even the most recent past. With television one is not conscious of anything that has happened, but of something which is *happening now, at this very moment.*

The thought was uppermost with me at this rehearsal. It may have been partly accounted for by the fact that I had been talking to Gus Chevalier and Doris Hare just before seeing them on the screen, but I could hardly forget there were a couple of flights of stairs between me and them, especially as I realised I might have been at home and seen them just the same.

That is the first and perhaps the most elementary thrill of television. It is happening *now*, as you see it, the division of time between them and

*(Continued on page 424.)*



# FERRANTI

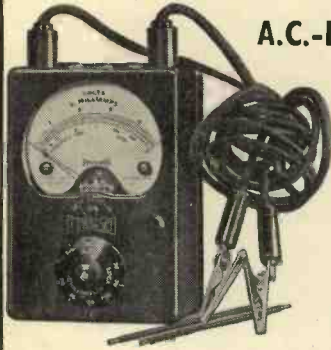

## A.C.-D.C. CIRCUIT TESTER

for the measurement of  
**A.C. VOLTAGE**  
**D.C. VOLTAGE**  
**D.C. MILLIAMPS AND RESISTANCE**

Price £5 : 15 : 0

Complete with External Resistance to give voltage ranges up to 600 volts.

An 0.5 mfd. plug-in Condenser Unit can be supplied (Price 5/-) to enable the instrument to be used directly to measure output voltages.

**RANGES.**

A.C. Volts.	A.C. Milliamps.	D.C. Volts.	D.C. Milliamps.	Resistance.
0-15	0-1	0-3	0-1	0-50,000 ohms self-contained and up to 30 megohms with external 600 volt supply.
0-150		0-15	0-7.5	
0-300		0-150	0-30	
~450		0-300	0-150	
0-600		0-450	0-750	
		0-600		

Write for Leaflet Wa 529.

**FERRANTI LTD., HOLLINWOOD, LANCS.**  
 London : Bush House, Aldwych, W.C.2.

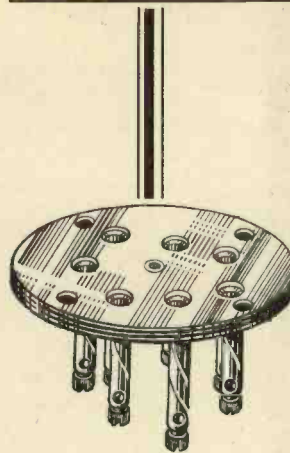

# CLIX

Chassis Mounting

## VALVE HOLDERS

ONLY CLIX Chassis Mounting Valveholders with their Resilient Sockets can provide that perfect contact between valve-pin and sockets which is essential for the efficient and silent working of Television and Radio apparatus. It is because of this reliable contact, super low-loss design and their sound construction that these Valveholders are continuously specified in the technical press.

STANDARD TYPE.

4-Pin, 8d. 5-Pin, 9d.

FLOATING TYPE.

7-Pin, 1/- 9-Pin, 1/3

AIRSPRUNG TYPE.

4-Pin, 1/2 5-Pin, 1/3

All models supplied without terminals at 3d. less on above prices.

CLIX American and Continental types also available.

1935 Folder "P.T." Now Ready. Gives details of over 30 CLIX perfect contact components.

CLIX SPECIFIED for the TELEVISION TRANSMITTER Described in this Issue.

# LECTRO LINX LTD.

79a, Rochester Row, London, S.W.1

## THE TELEVISION SOCIETY

President : Sir AMBROSE FLEMING, M.A., D.Sc., F.R.S.

Founded in 1927 for the furtherance of Study and Research in Television and allied Photo-electric Problems.

Ordinary Fellows are elected on a Certificate of Recommendation signed by Two Ordinary Fellows, the Proposer certifying his personal knowledge of the Candidate. The Admission Fee for Fellows is half-a-guinea, payable at the time of election, the Annual Subscription is £1 payable on election, and subsequently in advance on January 1st in each year, but the Annual Subscription may be compounded at any time by the payment of Ten Guineas.

Any person over 21, Interested in Television, may be eligible for the Associate Membership without technical qualifications, but must give some evidence of interest in the subject as shall satisfy the Committee. For Associate Members the Entrance Fee is 5/-, payable at the time of election, with Annual Subscription 15/-, payable in advance on January 1st in each year.

Student Members.—The Council has arranged for the entrance of persons under the age of 21 as Student Members, with Entrance Fee 2/6 and Annual Subscription 10/-, payable as above.

The Ordinary Meetings are held in London on the second Wednesday of the month (October to May inclusive) at 7 p.m. The business of the meetings includes the reading and discussion of papers. A Summer Meeting is usually held, and affords Members the opportunity of inspecting laboratories, works, etc. A Research Committee and the preparation of An Index of Current Literature are active branches of the Society's work.

### The Journal of the Television Society

is published three times a year. All members are entitled to a copy ; and it is also sold to Non-Members, at an annual subscription of 15/- post free.

Forms of proposal for Membership, and further information regarding the Society, may be obtained on application to the Business Secretary, J. J. Denton, 25, Lisburne Road, Hampstead, London, N.W.3.



## SOUND SALES TAKE THE LEAD

### FIRST WITH ALL-MAINS DRIVE

Cathode Ray Exciter Units. Time Base Units and 1500V Time Base H.T. & L.T. Units.

In addition to our special High Voltage Mains Transformers, 1500V Working Condensers etc. Stand 203 has something of particular interest to every serious minded experimenter.

### WE WANT YOUR ORDER

A visit to our Stand will convince you that WE deserve it.

SEE SOUND SALES SPECIAL ANTI-INTERFERENCE CHOKES ETC. (as supplied to the G.P.O.) on the Post Office Stands.

ONLY THE BEST DEALERS CAN STOCK SOUND SALES FAMOUS COMPONENTS ETC.

YOU MUST HAVE OUR NEW CATALOGUE

Specified by **SOUND SALES** the Experts

Contractors to **SOUND SALES Ltd.** the G.P.O. etc. Phone: Archway 1661-2 Highgate, London, N.19

Mention of "Television" will ensure prompt attention

## "I Watch a Rehearsal."

*(Continued from page 422)*

you being a minute fraction of a second only.

The value of gesticulation and facial expression was proved beyond doubt at one particular point in Gus Chevalier's turn. He sang a song called "But he did." Each verse led Gus into a fresh difficulty, and always the unexpected happened. He thought the other feller wouldn't—but *he did*. About the fifth verse he described how he was knocked down by a car at cross-roads. He didn't think the man would reverse and go over him again—but . . . and here he just waved his hands in despair while the piano played the phrase he should have sung. Amusing, of course, and how it demonstrated the value of television!

Naturally when a singer or a talker takes the screen the representation is in the form of a "close-up" just as in film-productions. If there are two, the honours are shared. I noticed how effectively this was done in a duologue between Mr. Chevalier and Miss Hare. When *she* spoke she was in the centre of the screen. Just as she was ending, her image

was moved to one side, and *he* appeared. The "Gun," as it is called, does all this. Mr. Chevalier and Miss Hare actually remained in their positions but the gun swung from side to side and each appeared at the right moment.

You can imagine that it is not easy to have moving figures in television because the televisor has to catch them and keep them more or less central. What then do you think of an attempt to televise three trick cyclists, gyrating in a space of twenty feet square? Yet it was done—and most effectively.

Moreover, it was done so smoothly and so quickly that I could hardly detect the movements of the televisor. Yet its movements never seemed to have the effect of causing the cyclists to appear to remain stationary, which which is what I thought might easily happen.

So far as that goes, part of *Carmen* has already been televised with costumes and scenery complete so that, within reason, nothing would seem impossible.

The room in which I sat was, of course, darkened. Curtains had been pulled across the window. As soon as a communicating door (into an-

other office) was opened the picture faded considerably. I measured out the distance I sat from the receiver. It was approximately fifteen feet. I walked nearer the receiver. After I had reduced the distance to about nine feet the picture appeared blurred.

That set me thinking again. What about short-sighted people? Wouldn't the picture blurr for them if they went nearer than that? I think the answer must be as Mr. Robb thought. He told me afterwards he thought they could certainly go a little nearer because of the effect of their glasses, but he considered that half-blind people must inevitably be in the same position as half-deaf people who listen to wireless.

I examined the receiver with interest. I found it to contain two switches for setting things in motion and two which controlled the lighting. Also there was a knob which framed the picture by which it was possible to adjust the whole scene and get it central, should it default in any way.

Television is wonderful!

Have you ever thought that, one day, it will be possible for one man to stand in view of the whole world? You can think that out for yourself. I confess it beats me.

## PHOTO-CONDUCTIVE CELLS

Photo-conductive cells differ from the known photo-electric cells in that the liberation of electrons from the cathode and their attraction to a positively charged anode as occurs in a photo-electric cell does not similarly occur in a photo-conductive cell.

Photo-conductive cells have the property of varying their electrical resistance when acted upon by light. The resistance, which is usually of the order of thousands of ohms in the dark is materially reduced when the light sensitive surface is acted upon by light.

### The Selenium Cell

The selenium cell is the most commonly known cell which has this property. Selenium is a chemical element which lies on the borderland between conductors and insulators. Normally selenium is a poor conductor of electricity, but its conductivity varies greatly when in the dark and illuminated.

The change in the electrical resistance of selenium was observed by Willoughby Smith in 1873. He was using thin rods of selenium as high resistance elements in an experimental circuit and found that the resistance of these elements was greatly reduced when sunlight fell on them.

The simplest selenium cell can be constructed by winding around a piece of slate, two thin bare copper wires having a very small space between each wire. These two wires will therefore be insulated from each other. If the slate is now heated and a thin layer of selenium rubbed on, it will fill the interstices between the wires. The whole cell is then cooled and the layer of selenium will be found to have a polished black surface and in this state is also an insulator. On further cautious heating of the cell the polished black surface will slowly assume a dull granulated form. In this form the selenium is now a conductor. The resistance of this grey selenium is now light sensitive and if connected in series with a galvanometer and battery, will show an increase in the current flowing if the selenium layer is illuminated. A careful heat treatment of the cell is usually carried out in order to increase the sensitivity.

Selenium cells are very sensitive to the violet and red rays of the spectrum, with a falling off of sensitivity in the blue, green and yellow regions.

Several other substances beside selenium have been found to be photo-conductive; amongst others may be mentioned thallium oxysulphide, prepared in 1920 by T. W. Case, and known as the thalofide cell. This cell is quite sensitive to the red and infra-red rays, having a maximum sensitivity at 1,000 millimicrons which is in the beginning of the heat rays.



## Constructors' Circle

### Additional Members

C. H. Ravenor, 29, Elmsdale Road, Walthamstow, E.17; A. S. C. Sanderson, Northmead, Farnham Common, Bucks; W. S. Millar, 10, Albert Road, East Cliff, Ramsgate, Kent; G. Mousley, 4, The Crescent, Weedon Road, St. James, Northampton; A. E. Chapman, Reddal Hill, Old Hill, Staffordshire; S. Harland, 66, Brewery Street, Harpurhey, Manchester; L. F. Hanney, 8, London Street, Walcot, Bath; J. Riley, 401, James Reckitt's Avenue, Hull, Yorks; D. J. Burgess, 14, Bridgen Street, Brighton, Sussex; S/Sgt. E. Mackenzie, R.A.O.C., 16c, Abbey Field, Colchester, Essex; C. G. Dixon, 2 Hamilton Terrace, Whitehaven; H. Jones, 251, Manchester Road, Frenchwood, Preston; J. Quirk, 6, Westbourne Road, Ramsey, Isle of Man; R. W. Dickson, 7, Assembly Street, Dumfries, Scotland; J. E. Freak, 26, Avenue Road, Redfern, South Australia; T. Arthur Jones, Radio House, Clydach, Swansea; G. Fleming, 13, Zulla Road, Nottingham; E. B. Taylor, 313, Spring Bank West, Hull, E. Yorks; J. Bramhill, 10, Orchard Waye, Uxbridge, Middlesex; W. F. Potts, 100, Stockport Road, Bredbury, nr. Stockport; W. Findlay, 31, Main Street, Cruden Bay, Aberdeenshire; E. Giles, Clifton Place, 29, Wood Street, Tunbridge Wells, Kent; K. B. Main, West End, Hinderwell, Yorks; G. A. McNair, 51, Dryburgh Avenue, Rutherglen, Glasgow; E. B. Armstrong, Audley Lodge, Ballymena, N. Ireland; S. A. Baker, "Five Ways," Merry-Hill, Wolverhampton; C. Kindred, Stone Farm, Gt. Glemham, Saxmundham, Suffolk.

## H. E. SANDERS & Co

SPECIALISE IN ALL APPARATUS FOR SCANNING DISC AND MIRROR DRUM PROJECTOR SYSTEMS, ETC.

OPTICAL UNIT for screen projection. Price £2-2-0. Lens extra 15/6.

THE "MERYVN" UNISPHERE MIRROR DRUM in kit form is now reduced to £2/15/- Post Free.

CRATER POINT LAMP, striking voltage 200-250; will carry 30 m/a.; now offered at 37/6, post 6d.

USE OUR SUPER LENS, 4" dia., and improve reception without distortion. Price 4/6, post extra 6d.

"MERYVN" NU-GLO LAMPS for 16" disc, 12/6, and 20", £1, post 6d.

DISC RECEIVER Kit of components. Price £2-14-0. Carriage paid.

Handbook "Easy Lessons in Television" 2/- post free.

Call and let us explain technical details.

Apparatus always available and can be sent C.O.D.

Send for Illustrated List.

## H. E. SANDERS & Co

4, GRAYS INN ROAD, LONDON, W.C.1

Telephone: Chancery 8778

## BOROUGH POLYTECHNIC

Borough Road, London, S.E.1

Electrical Engineering Department:

Head of Department:

W. C. S. Phillips, B.Sc., M.I.E.E., F.Inst.P.

Commencing 4th October, 1934, a Course of Lectures, illustrated by experiments and demonstrations, will be given on

## TELEVISION

on Thursdays, 8 - 9.30 p.m., by J. J. Denton

(Hon. Sec. Television Society).

Enrolments begin 17th September, 1934.

Further particulars may be obtained from the Principal.

## INDEX TO ADVERTISERS

British Television Supplies, Ltd.	Cover iv
Belling & Lee Ltd. . . . .	421
Borough Polytechnic Inst. . .	Cover iii
Bennett Television, Ltd. . . . .	Cover iii
Ferranti, Ltd. . . . .	423
Foyles Ltd. . . . .	Cover iii
General Electric, Ltd. . . . .	421
Lectro Linx . . . . .	423
Mervyn Sound & Vision Co., Ltd. . .	378
Plew Television, Ltd. . . . .	377
Peto Scott, Ltd. . . . .	417
Sanders, H. E., & Co. . . . .	Cover iii
Savage, Bryan . . . . .	421
Sound Sales . . . . .	423
Telephone Manufacturing Co. . . . .	Cover ii
Television Society . . . . .	423
Wireless Magazine . . . . .	Cover ii
Westinghouse Brake & Saxby Signal Co., Ltd. . . . .	419

## MISCELLANEOUS ADVERTISEMENTS

The charge for advertisements in these columns is 12 words or less 2/-, and 2d. for every additional word. All advertisements must be accompanied by remittance. Cheques and Postal Orders should be made payable to Bernard Jones Publications Ltd., and crossed, and should reach this office not later than the 15th of the month previous to date of issue.

A. MATHISEN, CHARTERED PATENT AGENT. Patents, Designs and Trade Marks.—First Avenue House, High Holborn, W.C.1. Holborn 8950. Telegrams: "Patam," Holb., London.

DOUBLE-ENDED MOTORS, 1/40 H.P. 15/-, 1/16 H.P. 19/-. Fitted with synchroniser 30/-. Complete synchroniser outfit 14/6. Synchroniser Coils 4/- pair. Kerr Cell 10/-. Complete Disc Receiver £2/5/0. 20" Scanning Disc 10/-. Illustrated list for stamp. Kingstone & Company, 372, Essex Road, London, N.1.

PATENTS—Trade Marks, Advice. Handbook and Consultations Free.—B. T. King, Patent Agent, G.B., U.S.A. and Canada. 146a, Queen Victoria Street, London. 48 years references. Phone: City 6161.

TELEVISION DISC KITS Complete 35/-, Receivers 35/-, Motors from 7/6, Discs 6/-, List Free, Melfo-Rad, Queens Place, Hove.

MOTORS, double-ended, 200/250 A.C./D.C., used perfect condition, 13/9; new motors, 18/6. Scanning discs, 7/6. Beehive neon, 3/8. Speed indicator, 1/- Synchroniser, tooth wheels, 3/6; best machine cut, 4/6; pair poles, 3/-; coils, 4/6. Complete synchroniser, including coils, 14/6; best, 19/9. Disc receiver constructor, illustrated, 1/3. Illustrated lists, used and new components, pamphlets, etc., free.—Ancei Cine Television Co., 16, Highbury Terrace, Nr. Highbury Station.

## Send to FOYLES FOR BOOKS!

New and second-hand books on every subject. Over two million volumes in stock. Catalogues free on mentioning your interests. 119-125, Charing Cross Road, London, W.C.2 Telephone—Gerrard 5660 (seven lines).



## BENNETT TELEVISION CO., REDHILL

Tel. 720

THE MOST GENEROUS VISION KIT. 75/6 EVERY PART FOR COMPLETE RECEIVER SCREWDRIER ASSEMBLED IN 15 MINUTES. BENNETT TOTALLY ENCLOSED VIEWING TUNNEL & NU-GLO LAMP ARE USED ENSURING BRIGHTEST PICTURES. ORDER TO DAY AND SEE FOR YOURSELF. BENNETT VIEWING TUNNEL (fitted with pair, non-distorting Lens), 16/6—FOR MERYVN, 54/6 KIT AND ALL DISC RECEIVERS. SPECIAL BI-CONVEX 4" LENS WITH METAL HOLDER, 6/6. LENS ONLY, 5/-. 1A.C./D.C. MOTORS. 20/-. SCANNING DISCS, 6/- & 7/6. NU-GLO LAMPS, 12/6. CRATER LAMPS, 37/6. "UNISPHERE" MIRROR DRUM KIT, 55/-. SCREW, 42/-. ALL TELEVISION COMPONENTS SUPPLIED. POST FREE OVER 10/-. LISTS FREE. Illustrated Constructors' Handbook, 1/-, post 2d.

## "TELEVISION" COUPON

FOR FREE INQUIRY SERVICE

Name \_\_\_\_\_

Address \_\_\_\_\_

September, 1934.

## THE CONSTRUCTORS' CIRCLE

Application for Membership

To be filled in and sent with a stamped envelope for reply to the Editor, "Television," 58-61, Fetter Lane, London, E.C.4.

(1) I already subscribe to your journal at the address below.

(2) I have placed a regular order for TELEVISION with my booksellers, Messrs.....

\* .....

and desire to be enrolled as a member of the TELEVISION "Constructors' Circle."

Please send membership badge free of charge to

Name (in block letters) .....

Address .....

.....

\*Strike out lines not applicable.

Mention of "Television" will ensure prompt attention



# B.T.S. INDIRECT DRIVE DISC TELEVISION RECEIVER

for *Efficiency*

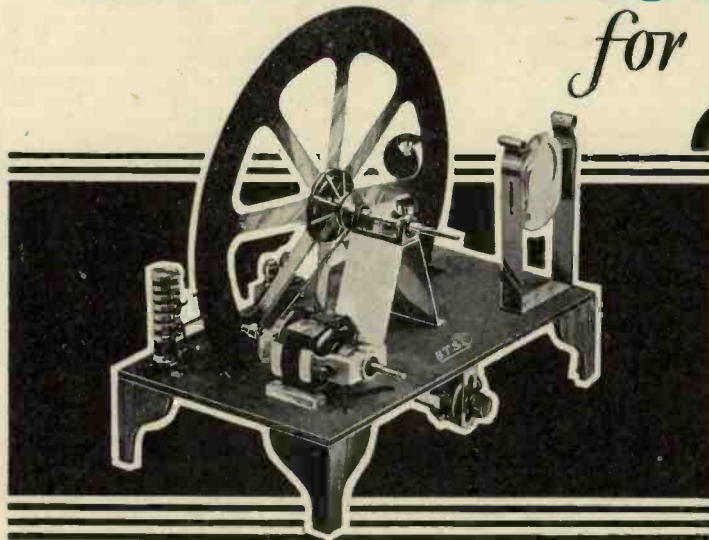

**COMPLETE KIT  
for HOME ASSEMBLY**

**84/-**

The B.T.S. DISC TELEVISION KIT comprises EVERY PART for instant assembly. Including B.T.S. Universal Ball-bearing Television Motor for either Mains or Battery operation as required; controlling resistances; laminated and ready-assembled chassis, with all component fixing holes marked. Stroboscope 16 in. Scanning disc and stand; lens and lens-holder; improved type TELEX Neon Lamp and Holder. FULL-SIZE BLUE-PRINT WITH ASSEMBLY WIRING AND OPERATING INSTRUCTIONS WITH EVERY KIT.

TYPE K12 for A.C. (40-60 cycles) and D.C. Mains, 84/-

TYPE K13 for 6-volt Battery, 78/-

AS SPECIFIED for the  
**MIRROR DRUM RECEIVER**

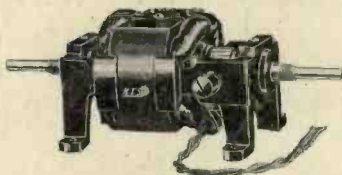

**B. T. S. TELEVISION MOTOR**

Runs with perfect precision. The heavy cast aluminium frame ensures freedom from mechanical vibration and absence of noise. Ball bearings provide even running. The motor is suitable for both 16 in. and 20 in. Scanning Discs. Cat. No. M/1 Universal A.C. or D.C. Mains, 200-240 volts. A.C. 40-60 cycles. Cat. No. M/2 6-volt Battery Type. **35/-**

I B.T.S. Motor Stand ... .. 2s. 6d.

**B.T.S. SYNCHRONISING GEAR KIT**

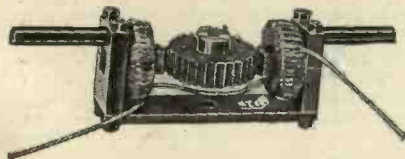

Perfect synchronisation, with floating images reduced to a minimum. Expertly designed and constructed. Kit includes Mild Steel frame with end bobbin supports, slotted for precise adjustment of pole pieces; two laminated pole pieces (assembled); two bobbins (ready wound); two ebonite handles for easy control. Quickly and easily assembled. For mounting on either end of B.T.S. Universal Motor.

In carton with assembly Instructions. **27/6**  
Cat. No. S/8. Complete Kit.

B.T.S. FIXED RESISTANCE as specified. **6/6**  
Cat. No. R/9

B.T.S. VARIABLE RESISTANCE as specified. **5/6**  
Cat. No. R/10

If required with B.T.S. Synchronising Gear - - 27/6 extra

TELEVISION is here! Past is the stage of early experiment and doubtful results. B.T.S. leading the way in this revolutionary new mode of entertainment, make the EFFICIENT reception of programmes in YOUR home as practical and inexpensive a proposition as ordinary Radio.

The outstanding efficiency and economy distinguishing the B.T.S. DISC TELEVISION RECEIVER is the outcome of patient and thorough research by acknowledged experts. The ease and rapidity with which steady pictures are to be obtained and maintained is the result of employing an improved indirect drive between the motor and scanning disc. Vast production resources enable this excellent Kit to be marketed at a price within the means of EVERYONE.

Working from any Mains Set or Battery Set (of 3 or more valves), the B.T.S. INDIRECT DRIVE DISC TELEVISION RECEIVER is easily assembled by the least experienced in half an hour, and requires no special tools or technical knowledge. You can enjoy televised programmes in YOUR home within an hour of purchasing the B.T.S. Kit from your local Radio Dealer. See him at once.

Obtainable from all First-class Radio Dealers.

# B.T.S.



● **MANUFACTURERS of TELEVISION APPARATUS** ●

BRITISH TELEVISION SUPPLIES, LTD. BUSH HOUSE, LONDON, W.C.2

Telephone: TEMPLE BAR 0134.

Telegrams: TELEVIEW, BUSH, LONDON

**WHOLESALE STOCKISTS:** Frank Riddiough & Son, Simes Street, Westgate, Bradford.  
J. Dyson & Co., Godwin Street, Bradford.  
Samuel Gratrix Jnr. & Bros., Ltd., Alport Works, Quay Street, Deansgate, Manchester.  
Boynnton's & Co., Ltd., 65-8, Stafford Street, Birmingham.  
Nottingham Radio Supplies, Ltd., Sherwood Buildings, Sherwood Street, Nottingham.